

ATTIC PLAN

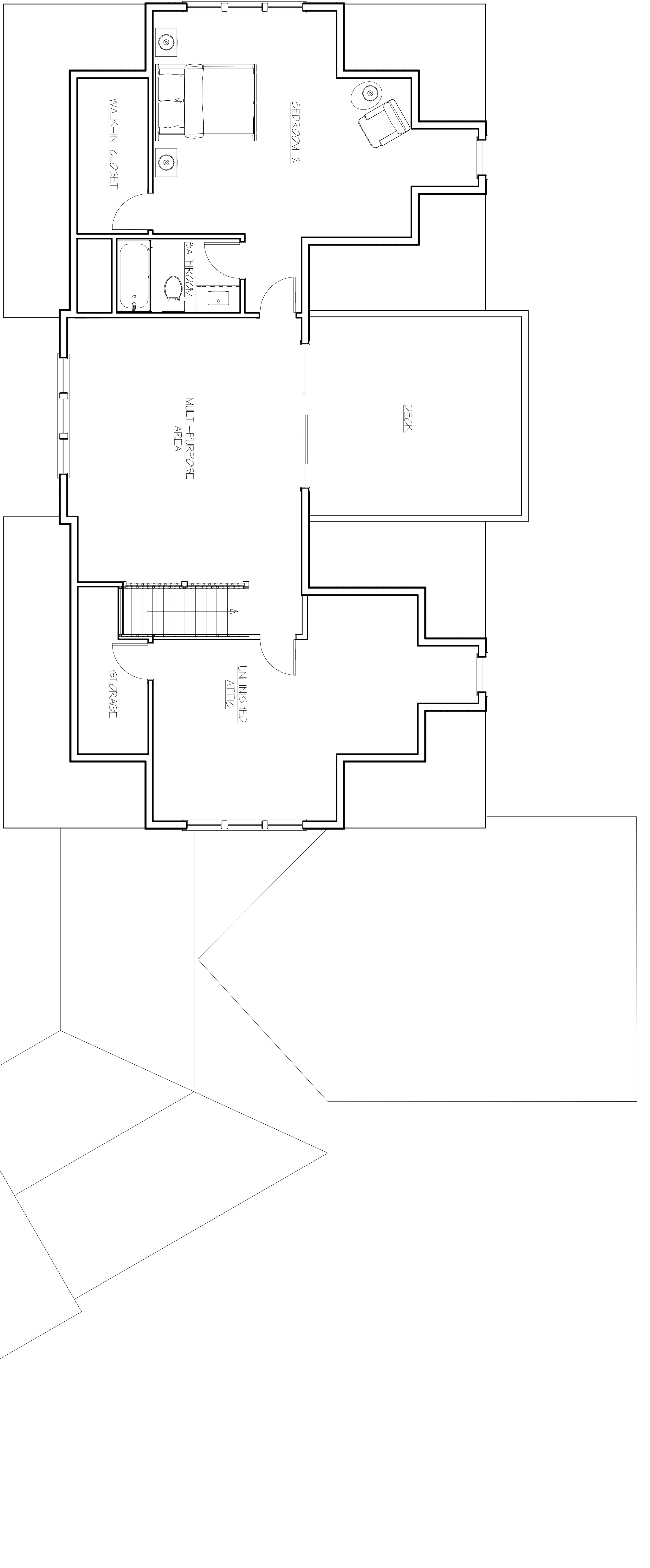

DWG TITLE  
FLOOR PLANS  
DATE: 10-20-21  
REV'D: 2-18-22  
SCALE: 1/4" = 1'-0"

THE CHAN RESIDENCE  
11 CLARK LANE  
ESSEX, CONNECTICUT

BROOKE GIRTY DESIGN  
261 GRASSY HILL ROAD  
LYME, CT. 06371  
860 434 1401

SHEET:  
A4



STEPS TO BASEMENT ACCESS

NORTH ELEVATION



WEST ELEVATION

BROOKE GIRTY DESIGN  
 261 GRASSY HILL ROAD  
 LYME, CT. 06371  
 860 434 1401

THE CHAN RESIDENCE  
 11 CLARK LANE  
 ESSEX, CONNECTICUT

DWG TITLE  
 ELEVATIONS  
 DATE: 10-20-21  
 REV'D: 2-18-22  
 SCALE: 1/4" = 1'-0"

SHEET:  
 A6

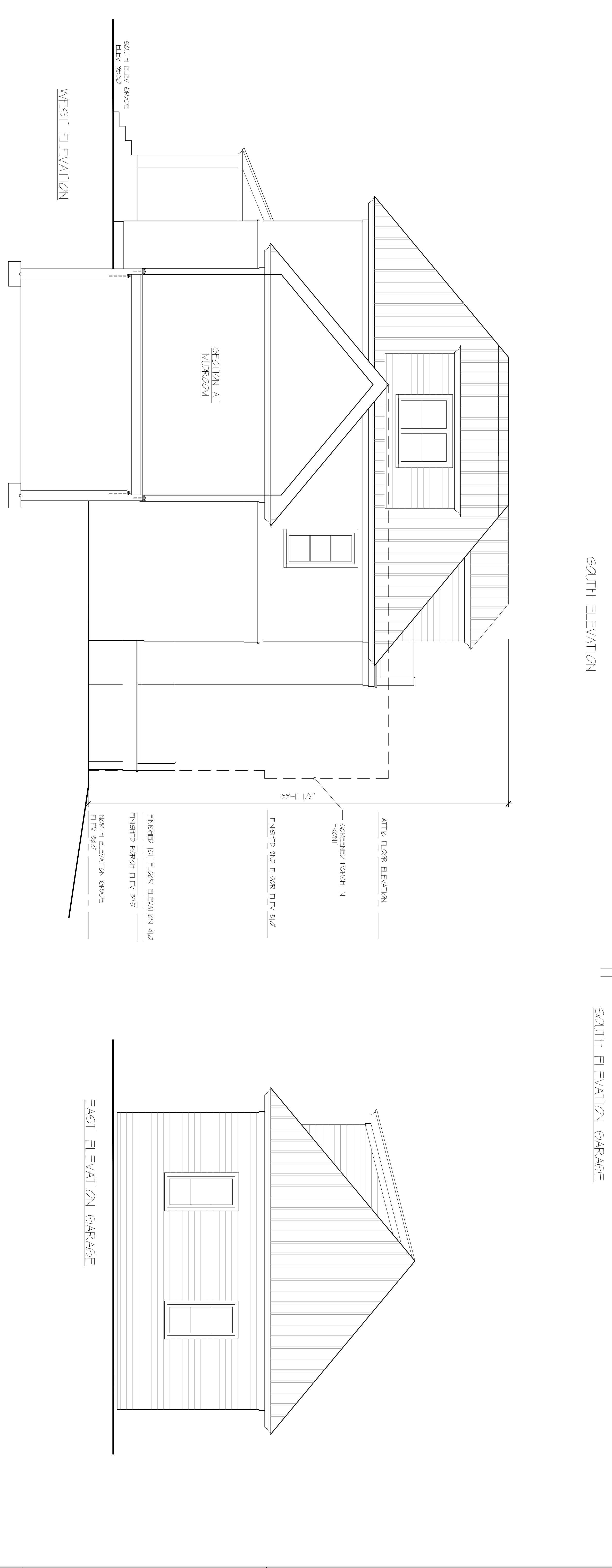
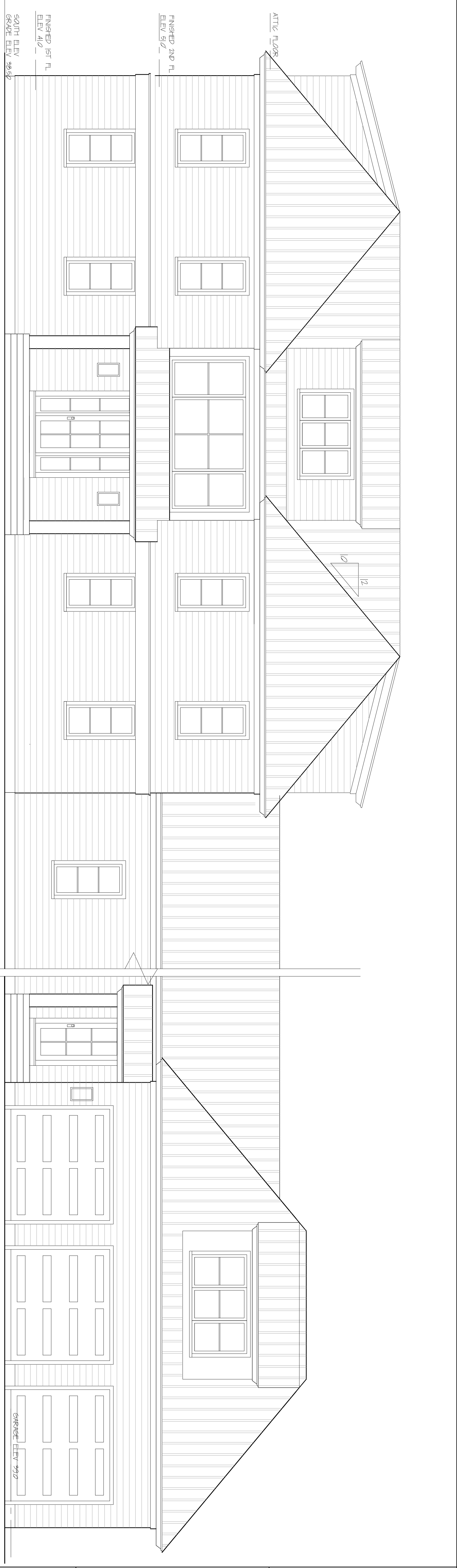

SHEET: A5	DWG TITLE ELEVATIONS DATE: 10-20-21 REV'D: 2-18-22 SCALE: 1/4" = 1'-0"	THE CHAN RESIDENCE 11 CLARK LANE ESSEX, CONNECTICUT	BROOKE GIRTY DESIGN 261 GRASSY HILL ROAD LYME, CT. 06371 860 434 1401	
--------------	--	---	--	--

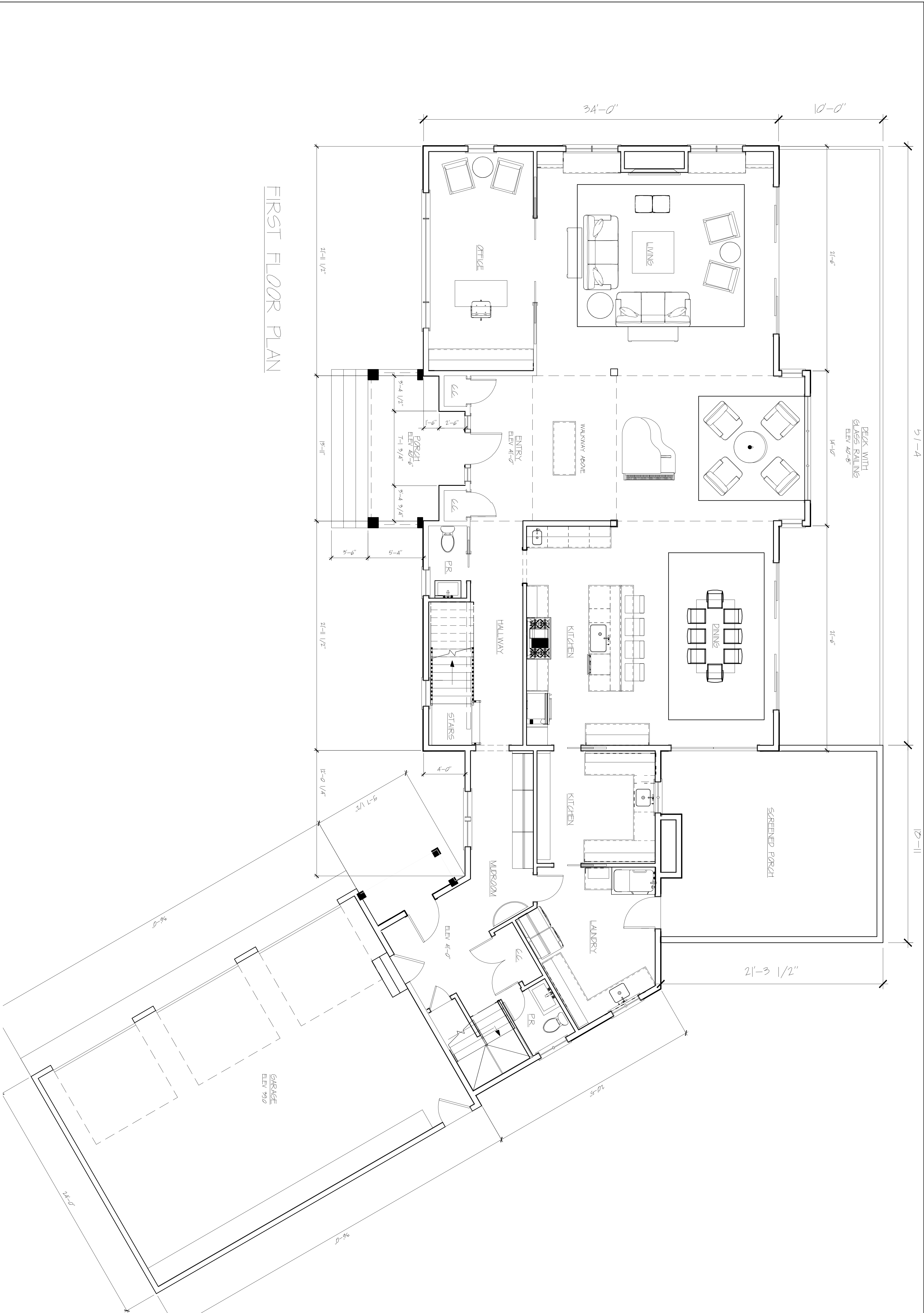

FIRST FLOOR PLAN

51-4

12-11

SHEET:  
A2

DWG TITLE  
FLOOR PLANS  
DATE: 10-20-21  
REV'D: 2-18-22  
SCALE: 1/4" = 1'-0"

THE CHAN RESIDENCE  
11 CLARK LANE  
ESSEX, CONNECTICUT

BROOKE GIRTY DESIGN  
261 GRASSY HILL ROAD  
LYME, CT. 06371  
860 434 1401

FOUNDATION PLAN

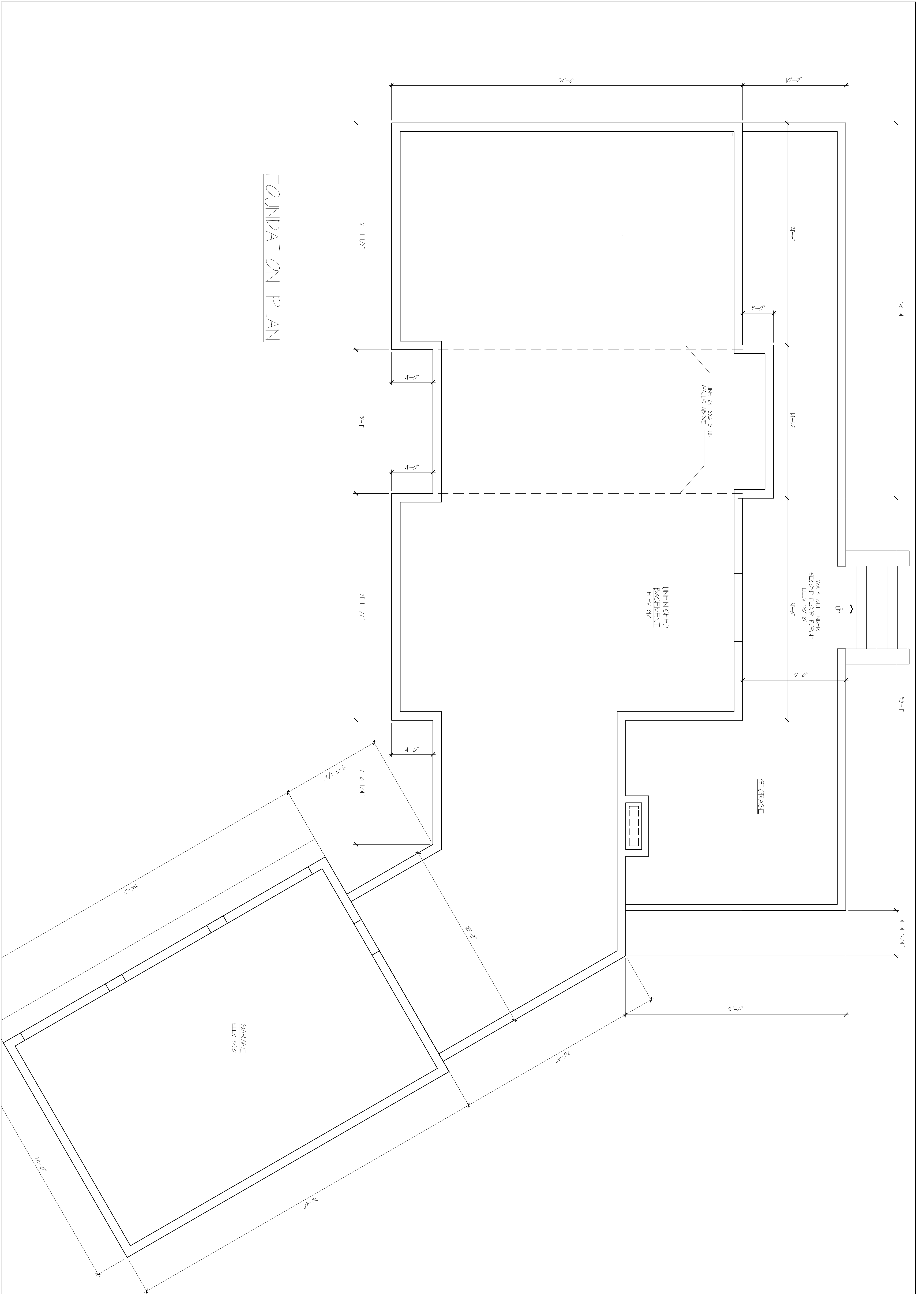

DWG TITLE  
FLOOR PLANS  
DATE: 10-20-21  
REV'D: 2-18-22  
SCALE: 1/4" = 1'-0"

SHEET:  
A1

THE CHAN RESIDENCE  
11 CLARK LANE  
ESSEX, CONNECTICUT

BROOKE GIRTY DESIGN  
261 GRASSY HILL ROAD  
LYME, CT, 06371  
860 434 1401

SECOND FLOOR PLAN

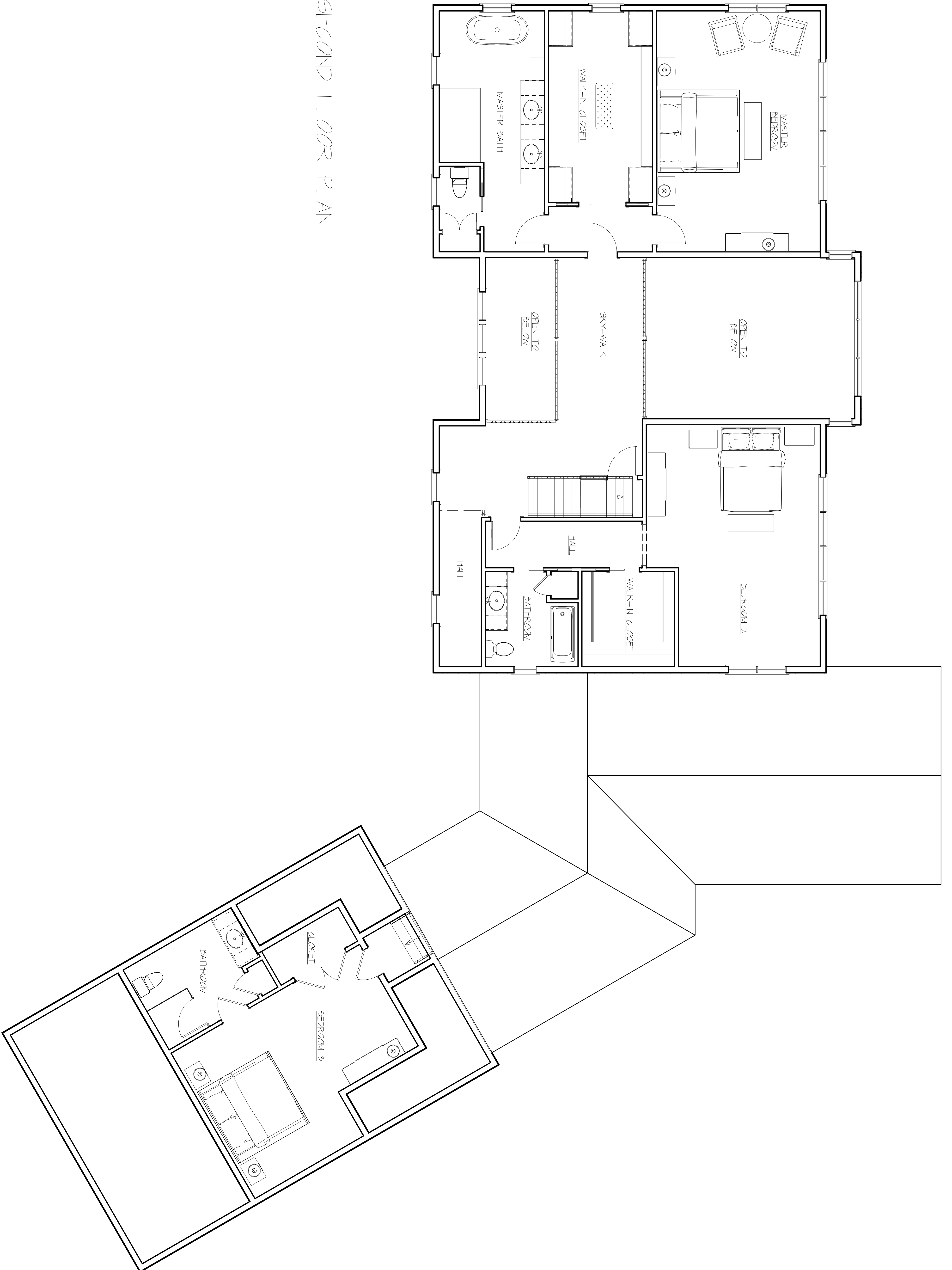

DWG TITLE  
 FLOOR PLANS  
 DATE: 10-20-21  
 REV'D: 2-18-22  
 SCALE: 1/4" = 1'-0"

SHEET:  
 A3

THE CHAN RESIDENCE  
 11 CLARK LANE  
 ESSEX, CONNECTICUT

BROOKE GIRTY DESIGN  
 261 GRASSY HILL ROAD  
 LYME, CT. 06371  
 860 434 1401

- Notes:**
- This map has been prepared in accordance with Sections 20-300b-1 through 20-300b-20 of the Regulations of Connecticut State Agencies - "Minimum Standards for Surveys and Maps in the State of Connecticut" as endorsed by the Connecticut Association of Land Surveyors, Inc. On September 26, 1996. This survey is a General Location Survey conforming to Horizontal Accuracy Class A-2 standards and Topographical Accuracy Class 1-2, is intended to be used for the layout and design of proposed improvements on this property.
  - Reference is made to the following maps:
    - "SUBDIVISION OF LAND OF DANIEL B. DOANE, CLARK LANE, ESSEX, CONN., SCALE: 1"=50', DATE: 05-27-76," by Richard W. Gates, File #24
    - FIRM FLOOD INSURANCE RATE MAP, MIDDLESEX COUNTY, CONNECTICUT, MAP NUMBER 09007C032G, REVISED 08-28-08", by Federal Emergency Management Agency.
  - Lot is located within the RU zone and the Connecticut River Gateway Commission.
  - Lot area = 62,712 sq. ft. ± or 1.4397 acres ±.
  - Topographic information depicted on the drawing is based on a field survey conducted by this office on November 19, 2021. All existing features and conditions are not necessarily depicted or noted hereon. Property line information shown on the drawing is approximate only and is provided for the contractor's general information.
  - All elevations are referenced to the North American Vertical Datum of 1988.
  - Water supply shall be provided by on-site well.
  - Public utilities' service connections to the building shall be installed underground.
  - Separating distances from closed loop geothermal well may be reduced from 75' if a licensed well driller installs boreholes with permit certifying construction standards per DPH EHS circular letter #2007-12.
  - It is the intent of this design that the bottom of the proposed system be installed no more than 43' below original grade (Deep Test Pit 1, total depth 91').
  - No revision to this design shall be made without the written approval of the design engineer and the knowledge and consent of the Essex Health Department.
  - All work shall conform to the regulations and standards of the Essex Health Department and the Connecticut Public Health Code, regulations and technical standards for subsurface sewage disposal systems, latest revision.
  - The location, dimensions and elevations of the foundation of the building to be served shown on the drawing are based upon information provided to the engineer. The contractor shall coordinate this drawing with the architectural drawings and verify that the information shown is correct before proceeding with the work.
  - For bathtubs with a capacity of 100 to 200 gallons add 250 gallons to the capacity of the septic tank. For tubs in excess of 200 gallons, add 500 gallons to tank capacity.
  - No provisions have been made in the septic system design to accommodate a garbage disposal unit installed in the building served. They are not recommended for use. Should one be proposed, add 250 gallons to the required capacity of the septic tank.
  - Per the Connecticut Public Health Code, waste from a water treatment wastewater (wtw) system meeting Appendix E generated by a private water supply system (i.e. well) shall discharge to a primary subsurface sewage disposal system. If they do not meet the specifications in Appendix E, these wastewaters shall be discharged into a separate leaching system.
  - Prior to the start of construction, the contractor shall thoroughly review the drawing and the project site, and familiarize themselves with all existing conditions and features.
  - Underground utility locations depicted (if any) are approximate only and are provided for the contractor's general information. The contractor shall be responsible for locating all underground utilities and for the maintenance and protection thereof. The contractor shall contact call-before-you-dig (800-922-4455) prior to construction activity to have the underground utilities located and marked on the ground. The contractor shall notify the engineer in the event an underground utility that is not located is discovered or uncovered during construction.
  - Design elevations of the septic system are based upon the results of soils tests conducted in the locations shown on the drawing. The contractor shall notify the engineer if subsurface conditions encountered differ materially from those shown.
  - Additional soil testing may be required by the Essex Health Department prior to system construction.
  - The contractor shall notify the engineer and the Essex Health Department at least two days prior to both the planned start of septic system construction and the backfilling of the completed system.
  - All trees, shrubs and other vegetation shall be removed, and all topsoil shall be stripped from within the fill limits shown hereon. Native fill or common fill used in the embankment adjacent to the select fill shall be clean suitable material, free of boulders, stumps and/or other debris. All existing fill, organic material and other unsuitable soil shall be removed from the system area. All vehicular traffic and construction equipment shall be kept off exposed soils in the system area.
  - The responsibility for the preparation of a leaching area utilizing select fill material is that of the licensed installer. The installer shall take the necessary steps to protect the underlying naturally occurring soils from overcompaction and sitation once exposed. Select fill used in the leaching field area shall meet the gradation requirements set forth in the technical standards of the Connecticut Public Health Code (section viii.A, as amended), and in no case shall contain greater than 6% by weight passing the #200 wet sieve. The percolation rate of the select fill shall be equal to or faster than that of the underlying soil. Select fill shall be placed in layers not to exceed 12 inches in depth. The entire area of each layer shall be compacted by suitable equipment, capable of achieving an approximate dry density of each lift of not less than 90% of the maximum as achieved by ASTM D 1557, method C. For leaching systems entirely in select fill a percolation test of the select fill is required after fill placement to confirm fill suitability.
  - Wheel loading rated H-20 septic tank including riser and cover assemblies to be installed. Septic tank shall be manufactured per ASTM C-1227-95 standards. Outlet filter shall be as manufactured by Zabel, or approved equal. An access riser shall be provided over each manhole opening where ever there is 12" or more of cover over the septic tank. The minimum inside diameter of the riser shall be 18" for cover depths up to 2 feet, and 24" for cover depths greater than 2 feet. Riser cover shall weigh a minimum of 59 lbs, or shall be fitted with a locking cover.
  - A record drawing of the completed system shall be completed by the design engineer and submitted to the Essex Health Department prior to the final inspection by the sanitarian.
  - The completed septic system shall be properly covered within two working days following the final field inspection and approval by the Essex Health Department. The ground surface over the entire subsurface sewage disposal system area shall be graded and maintained to lead surface water away from the area. All disturbed areas shall be loamed, seeded and mulched as soon as is practical after the completion of final grading.
  - The contractor shall provide and maintain erosion and sediment controls as shown on the drawing or as directed. Erosion and sediment controls shall be maintained until all disturbed areas have been stabilized.
  - No underground fuel oil tank shall be installed without a specific permit from the Town of Essex.
  - Abandonment of existing septic tanks or other hollow leaching structures (if any) shall be performed in conformance with Technical Standards Section II D. of the Connecticut Public Health Code in such a manner as to minimize the danger of inadvertent future collapse of the structure. The chamber shall be emptied of all septage wastes, crushed and backfilled in place with clean soil.
  - Construction within a Flood Zone(s) shall conform to all ASCE and FEMA standards. Requirements shall be verified with the Town Building Department and Flood Plain Administrator.
  - The parcel is within both the Flood Zone AE10 and the Flood Zone X per the reference map (b.).

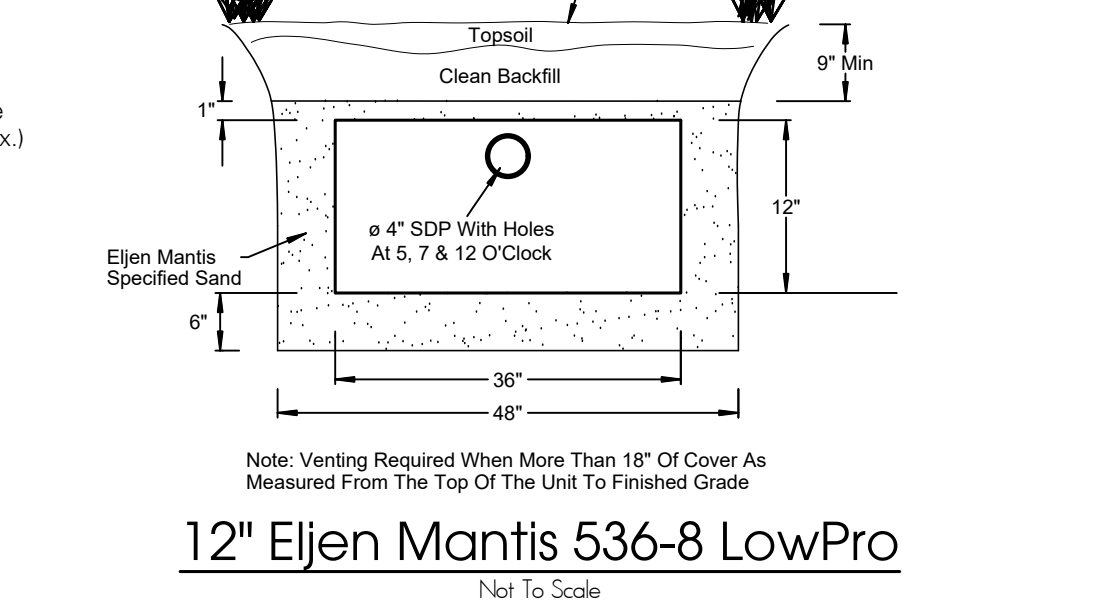
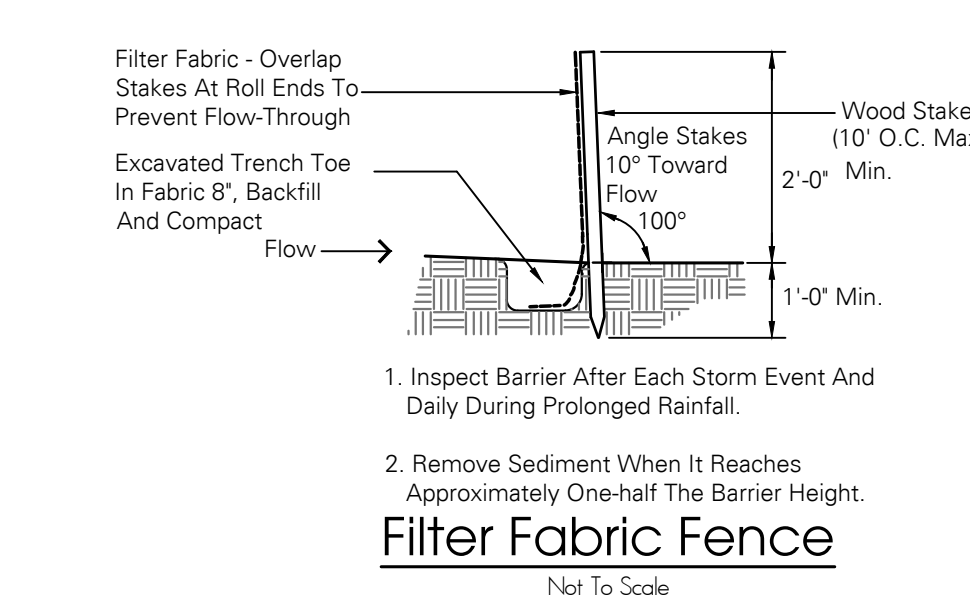
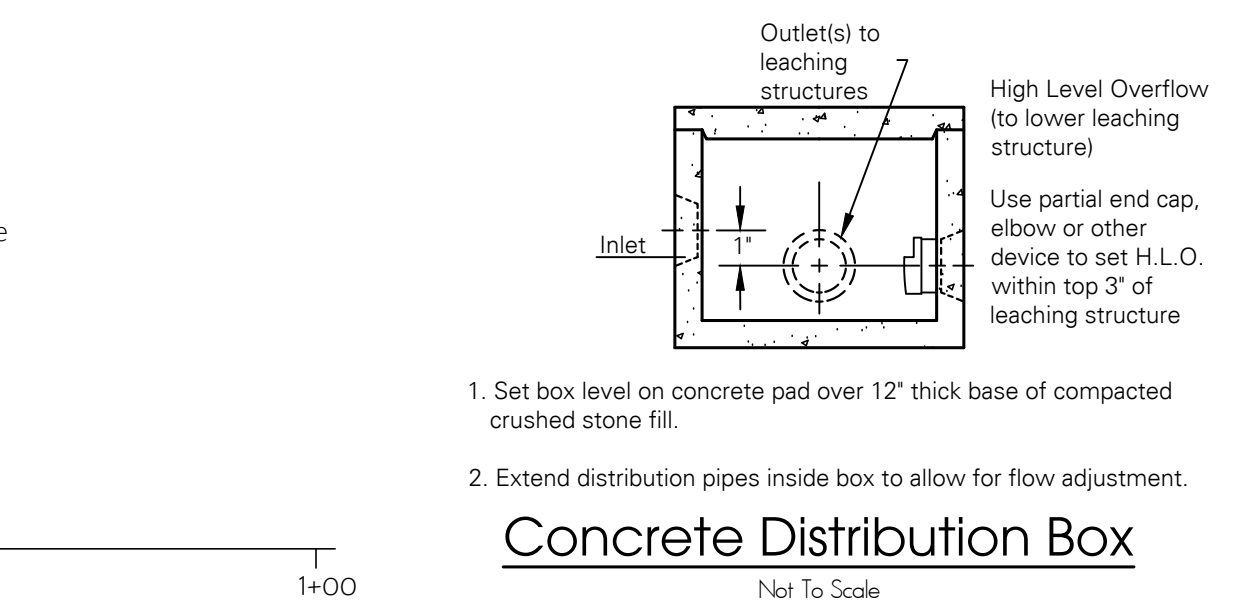
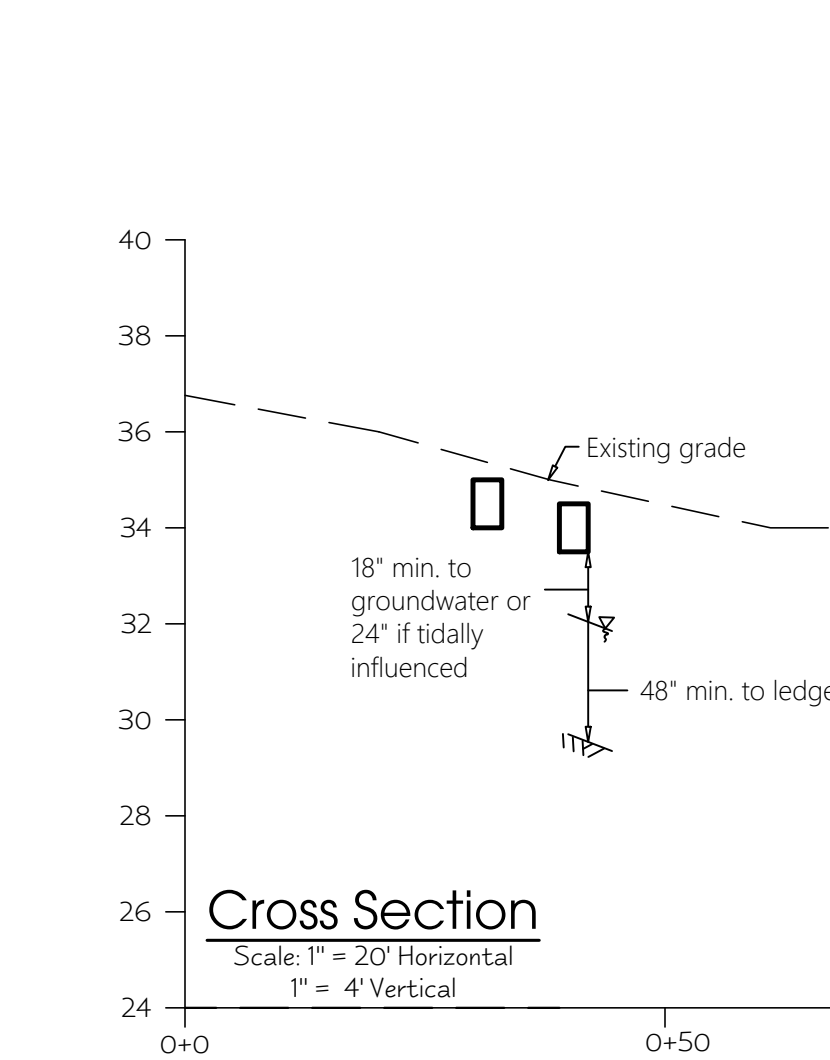
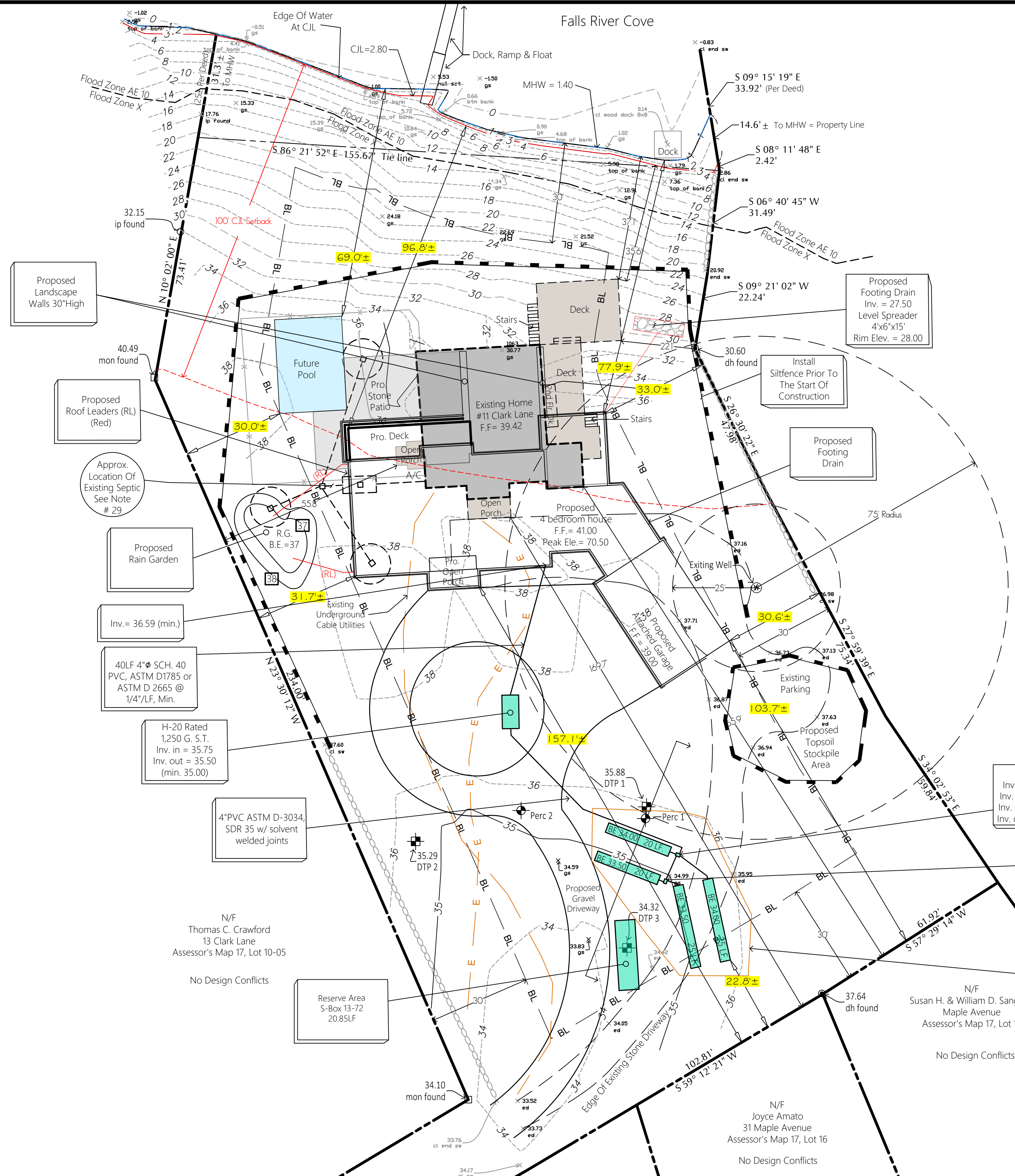

### Zoning Requirements

Description	Required / Allowed	Existing	Proposed
Lot Area	80,000 sq. ft.	62,712 sq. ft.	62,712 sq. ft.
Front & Rear Setback	40' & 30'	N/A	N/A
Side Setback (N)	30'	37.1'	69.0' ± Pool / 77.9' ± Hse
Side Setback (E)	30'	22.1'	30.6' ±
Side Setback (W)	30'	55.8'	30.0' ± Pool / 31.7' ± Hse
Side Setback (S)	30'	165.9'	157.1'
Avg. Bldg. Height	-	-	-
Total Bldg. Height	35'	44.2'	34.92'
Coverage	15%	4.4% or 2,726 sq. ft.	8.0% or 5,016 sq. ft.
Floor Area	-	2,344 sq. ft.	4,931

\*Floor Area existing per the Assessor's Field Card & Proposed as per Architect.

### Rain Garden Sizing Calculations

Roof Area = 4,364 Sq.Ft.  
 \*Assume 1" Rainfall Generates 90% Runoff  
 4,364 Sq.Ft. x 1/12 x 90% = 327.3 Ft.<sup>3</sup> Garden Volume Required  
 472 @ El. 38.0 + 228 @ El. 37.0 x 1.00 Deep = 350 Ft.<sup>3</sup>  
 350 Ft.<sup>3</sup> > 327.30 Ft.<sup>3</sup> O.K.

### Bio Retention Area (Rain Garden)

Suggested Planting List  
 \*All Plants To Be Native Non-Invasive Species

Common Name	Scientific Name
Wolf Sedge	<i>Carex lasiocarpa</i>
Soft Rush	<i>Juncus effusus</i>
Leatherwood	<i>Dirca palustris</i>
Blue Flag Iris	<i>Iris versicolor</i>
Tickseed sunflower	<i>Bidens aristosa</i>
Black-eyed Susan	<i>Rudbeckia hirta</i>

\* Suggested plantings may be replaced with alternates provided in "RAIN GARDENS in Connecticut" by UConn Cooperative Extension System.

### Legend

— N 12°34'56" E	Property / Right Of Way
--- S 12°34'56" W	Easement
— BL —	Building Setback Line
— 10.4 —	Existing Elevation Contour
x104.2	Existing Spot Elevation
— 106 —	Proposed Elevation Contour
□	Proposed Spot Elevation
□	Concrete Monument
○	Iron Pipe / Rebar
●	Drill Hole
PP ○	Fence Post (Barbed Wire)
N/F	Now or Formerly
—	Fence
—	Filter Fabric Sediment Barrier
⊕	Test Pit / Soils Test
⊕	Percolation Test
— E —	Percolation Electrical Wires

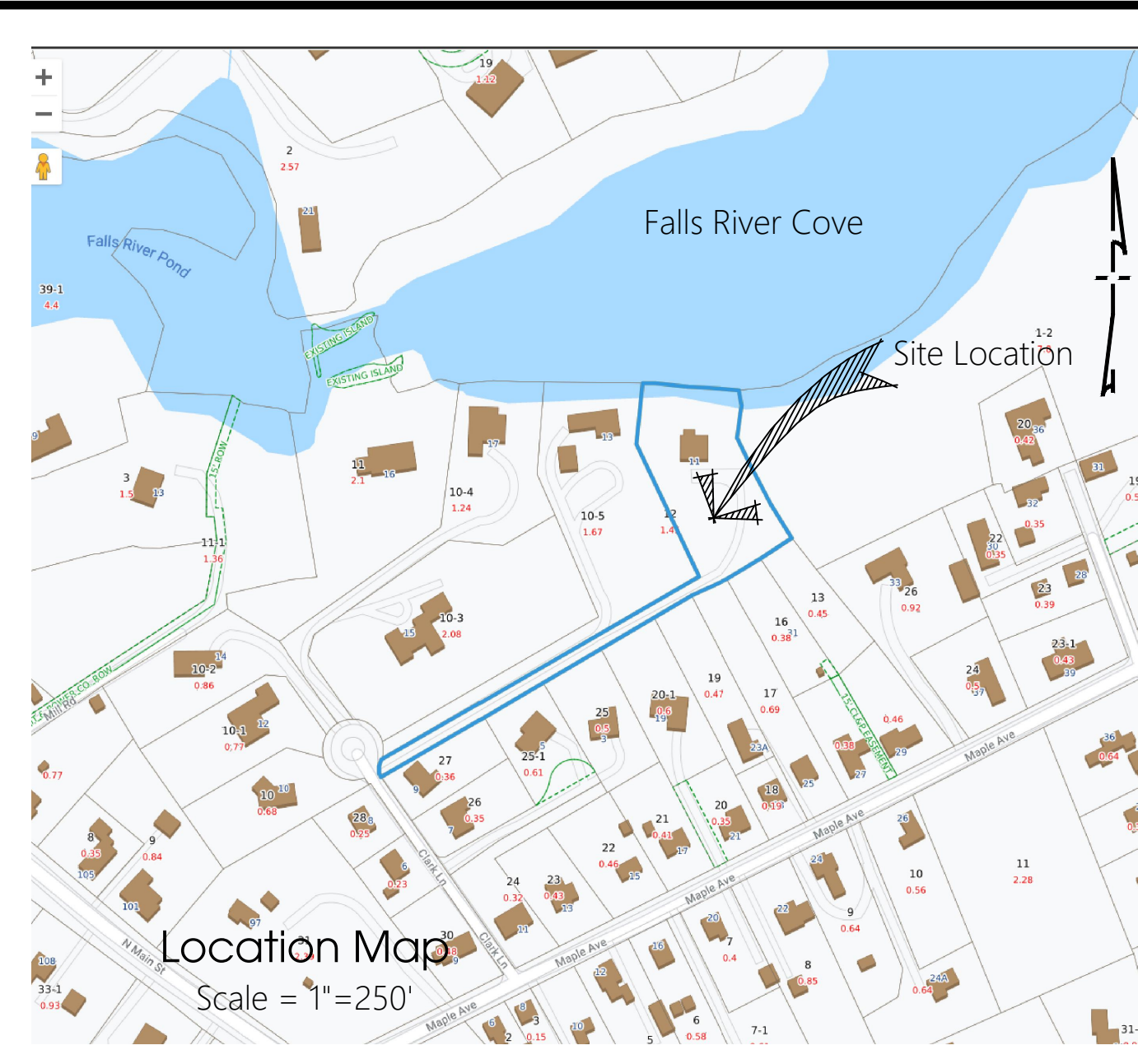

### Test pit observations

Test pits observations on 11-09-21 by Lisa Fasulo, REHS/RS and Thomas A. Stevens & Associates, Inc.

TP	Depth	Soil Description	Notes
TP 1	0 - 10"	Topsoil	
TP 1	10 - 24"	Brown, fine sandy loam	
TP 1	24 - 63"	Olive-brown, medium sand	
TP 1	63 - 91"	Light brown, medium-coarse sand	
TP 1	91 - 110"	Light brown, medium-coarse sand	
TP 2	0 - 11"	Topsoil	
TP 2	11 - 33"	Brown, fine sandy loam	
TP 2	33 - 54"	Olive-brown, medium sand	
TP 2	54 - 93"	Light brown, medium-coarse sand	
TP 2	93 - 109"	Light brown, medium-coarse sand	
TP 3	0 - 09"	Topsoil	
TP 3	09 - 28"	Brown, fine sandy loam	
TP 3	28 - 50"	Olive-brown, medium sand	
TP 3	50 - 107"	Light brown, medium-coarse sand	

### Percolation test data

Percolation tests performed on 11-10-21 by Thomas A. Stevens & Associates, Inc.

Perc	Depth	Start Time	Percolation Rate
Perc 1	7:06 9-1/2"	Total Depth: 22-1/4"	Start Time: 7:06 AM
Perc 1	7:11 15-1/4"		
Perc 1	7:16 17-7/8"		
Perc 1	7:26 21-1/2"		
Perc 1	7:31 22-1/4" DRY		
Perc 2	7:13 9-1/4"	Total Depth: 21-3/4"	Start Time: 7:13 AM
Perc 2	7:18 13-3/4"		
Perc 2	7:23 15-3/4"		
Perc 2	7:28 17-1/8"		
Perc 2	7:33 18-3/8"		
Perc 2	7:38 19"		
Perc 2	7:43 20-1/8"		
Perc 2	7:48 21-3/4" DRY		
Perc 2	7:58 22-1/4" DRY		

### System design calculations

The design of the sewage disposal system is based upon a percolation rate of 1.0-10 minutes per inch for a 4 bedroom residential building at 150 gallons per bedroom. Per the Connecticut Public Health Code the effective leaching area required is 577.5 sf. Total effective leaching area provided = (2 @ 45 lf) @ 6.5sf/lf = 585 sf.

Minimum leaching system spread calculations:  
 Restrictive layer >60" = no MLSS required.

**Thomas A. Stevens & Associates, Inc.**  
 Civil Engineers • Land Surveyors  
 141 Durham Road, Unit 24  
 P.O. Box 568  
 Madison, Connecticut  
 06443-0568  
 phone: (203) 245-0149  
 or (860) 373-0260  
 fax: (203) 245-0731  
 email: civil911@gmail.com  
 web: www.civilsurvey.org

TO THE BEST OF MY KNOWLEDGE AND BELIEF THIS MAP IS SUBSTANTIALLY CORRECT AS SHOWN HEREON.

Thomas A. Stevens, P.E. 02121, C.T. Reg. No. 100203  
 The above licensed Civil Engineer and Land Surveyor.

Improvement Location Survey - Proposed

Site Plan & Septic Design

Prepared For Douglas Chan  
 Assessor's Map 16, Lot 01-02

11 Clark Lane  
 Essex, Connecticut

Revisions	Date	By	Checked
1	11-19-21	Thomas Wilcox	DSS
2	12-07-21	Thomas Wilcox	Thomas Stevens
3	12-05-21	Thomas Wilcox	Thomas Stevens
4	02-18-22	Thomas Wilcox	Thomas Stevens
5	02-16-22	Thomas Wilcox	Thomas Stevens

C-1