

DATE	REVISION	CK.
12/12/22	TOWN COMMENTS	
01/06/23	TOWN COMMENTS	
01/10/23	REVISIONS	
02/06/23	TOWN COMMENTS	
02/10/23	BASEIN PLANTING/BUILDING HEIGHT	

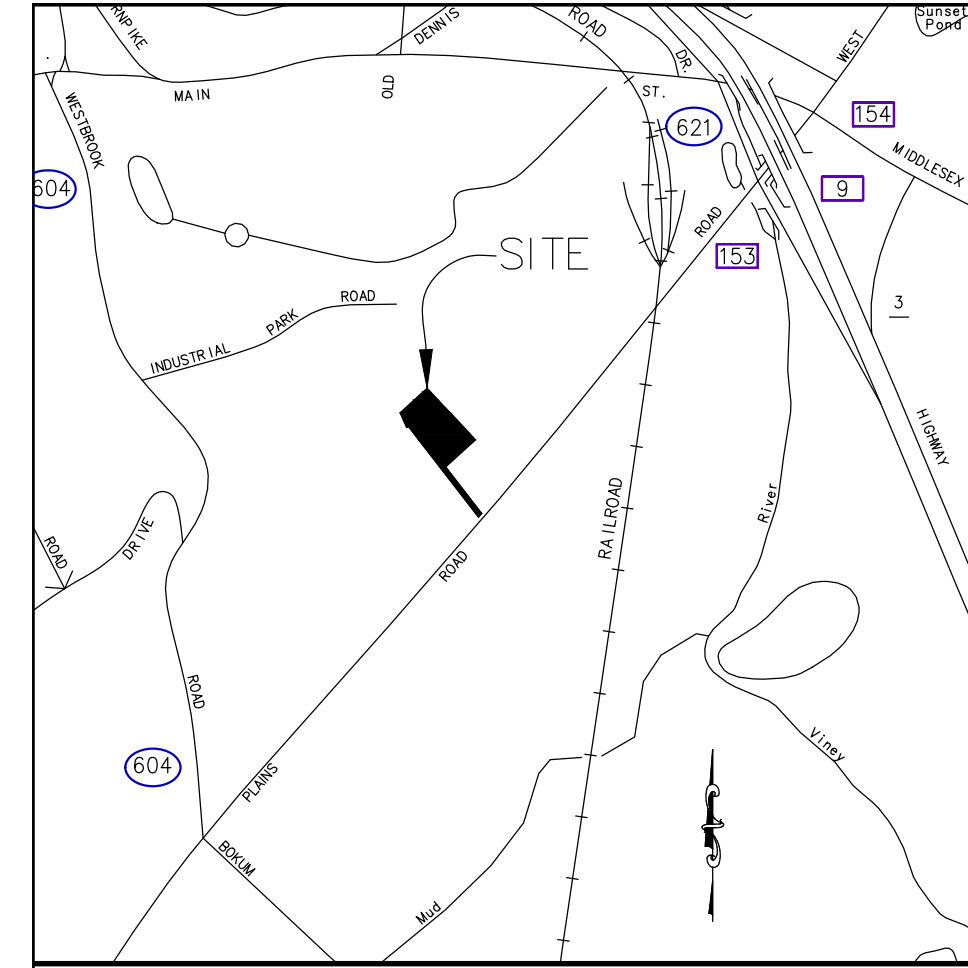

LOCATION MAP  
SCALE: 1"=1000'±

N/F  
STRAND PROPERTIES LLC  
VOL. 325 PAGE 677  
"NO DESIGN CONFLICTS"

N/F  
BOMBACI GLORIA A  
VOL. 266 PAGE 118  
"NO DESIGN CONFLICTS"

N/F  
HYDRATION LLC  
VOL. 177 PAGE 426  
"NO DESIGN CONFLICTS"

N/F  
HYDRATION LLC  
VOL. 177 PAGE 426  
"NO DESIGN CONFLICTS"

N/F  
45 PLAINS ROAD LLC  
VOL. 249 PAGE 856  
"NO DESIGN CONFLICTS"

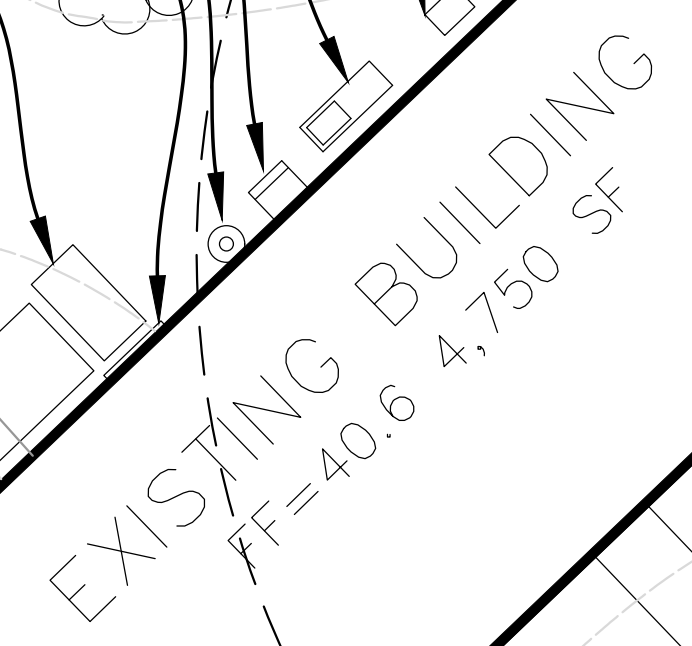
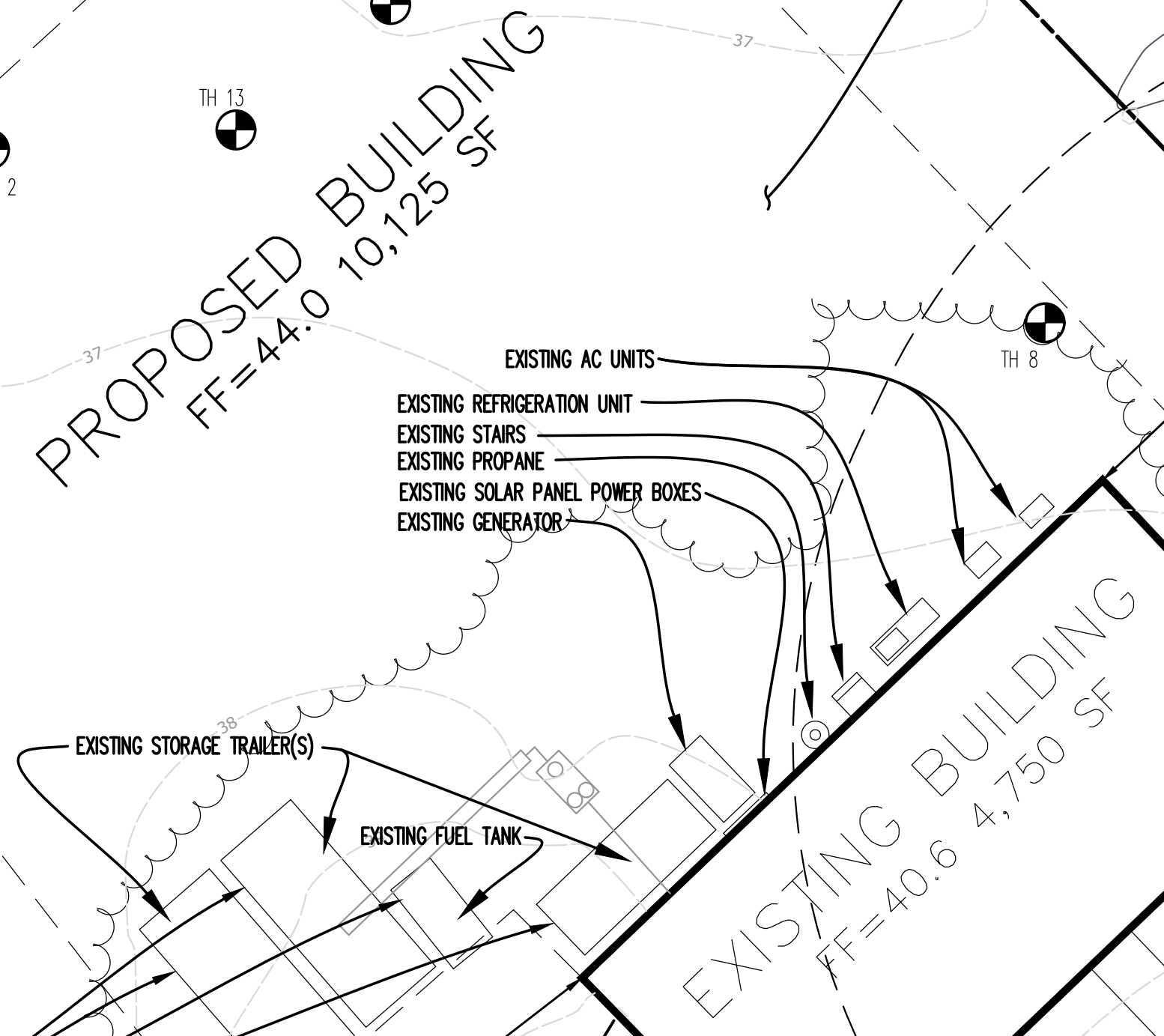

- LEGEND**
- IRON PIPE/ROD TO BE SET
  - MON □ MONUMENT
  - IP ○ IRON PIPE/ROD
  - FP ○ FENCE POST FOUND
  - CONC. CONCRETE
  - DIST. DISTURBED
  - (PRM) PER REF MAP
  - FND FOUND
  - FF FINISHED FLOOR
  - EXIST. EXISTING
  - CL&P# 1198 ○ EXISTING UTILITY POLE
  - TH#1 ● TEST HOLE
  - + [7.0] PROPOSED SPOT ELEVATION
  - - - 40 - - - EXISTING CONTOURS
  - - - SF - - - SILT FENCE
  - - - FW - - - PROPOSED WATERLINE

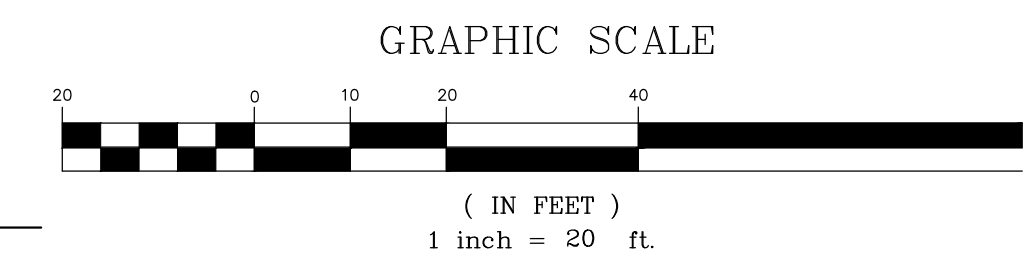

THIS SURVEY AND MAP HAS BEEN PREPARED IN ACCORDANCE WITH SECTIONS 20-300b-1 THRU 20-300b-4 INCLUSIVE OF THE REGULATIONS OF CONNECTICUT STATE AGENCIES AND "RECOMMENDED MINIMUM STANDARDS FOR SURVEYS AND MAPS IN THE STATE OF CONNECTICUT". IT IS AN IMPROVEMENT LOCATION SURVEY AND IS INTENDED TO DEPICT EXISTING AND PROPOSED CONDITIONS IN RELATION TO EXISTING BUILDING LINES. PROPERTY/BOUNDARY HAS BEEN DETERMINED BY A DEPENDENT RESURVEY WITH REFERENCE TO THE MAPS LISTED HEREON. THIS SURVEY IS SUBJECT TO SUCH FACTS AS AN INDEPENDENT RESURVEY MAY DISCLOSE.

A.) EVERGREEN INDUSTRIAL PARK SUBDIVISION OF LAND PROPERTY OF WILLIAM K. RUTAN CONN. ROUTE 153 - PLAINS ROAD ESSEX, CONN. DATED 2-20-84 SCALE: 1"=50' BY DONALD R CARLSON

THE SUBJECT PROPERTY CONTAINS 87,763 SF 2.0 AC

HORIZONTAL ACCURACY CONFORMS TO CLASS A-2. HORIZONTAL COORDINATES AND DIRECTIONS DEPICTED HEREON ARE BASED ON A LOCAL GRID RELATED TO THE NORTH AMERICAN DATUM OF 1983 (NAD83). ALL DISTANCES ARE IN U.S. SURVEY FOOT. THE BASIS OF HORIZONTAL DATUM ARE CONNECTICUT GEODETIC SURVEY MONUMENTS: CGS 5009 (ESSEX) CGS 5010 (ESSEX). THEREFORE THE BEARINGS SHOWN HEREON DIFFER FROM THE BEARINGS SHOWN ON REFERENCE MAP A.

VERTICAL ACCURACY CONFORMS TO CLASS T-2 (ASSUM DATUM)

SUBJECT PROPERTY IS RECORDED IN TOWN OF ESSEX LAND RECORDS VOL. 300, PG 448

TO MY KNOWLEDGE AND BELIEF, THIS MAP IS SUBSTANTIALLY CORRECT AS NOTED HEREON.

*Robert L. Doane, Jr.*  
ROBERT L. DOANE, JR.  
CONN. P.E. & L.S. LIC. NO. 11463

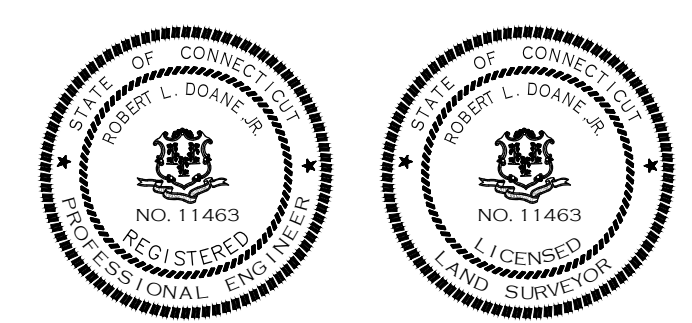

"EXISTING CONDITIONS SITE PLAN"  
MAP #45 LOT #27-3

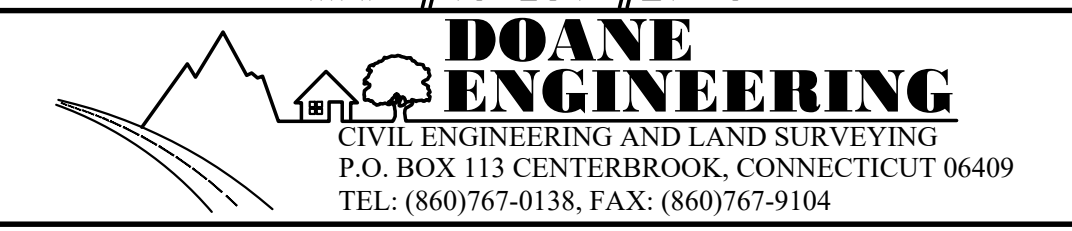

SITE PLAN PREPARED FOR PIAGE MANAGEMENT CORP #49 PLAINS ROAD, ESSEX, CONNECTICUT			
SCALE: 1"=20'	DATE: 11/03/22	SHEET NO.: 1 OF 7	IDENT. NO.:

DATE	REVISION	CK.
12/12/22	TOWN COMMENTS	
01/06/23	TOWN COMMENTS	
01/10/23	REVISIONS	
02/06/23	TOWN COMMENTS	
02/10/23	BASEIN PLANTING/BUILDING HEIGHT	

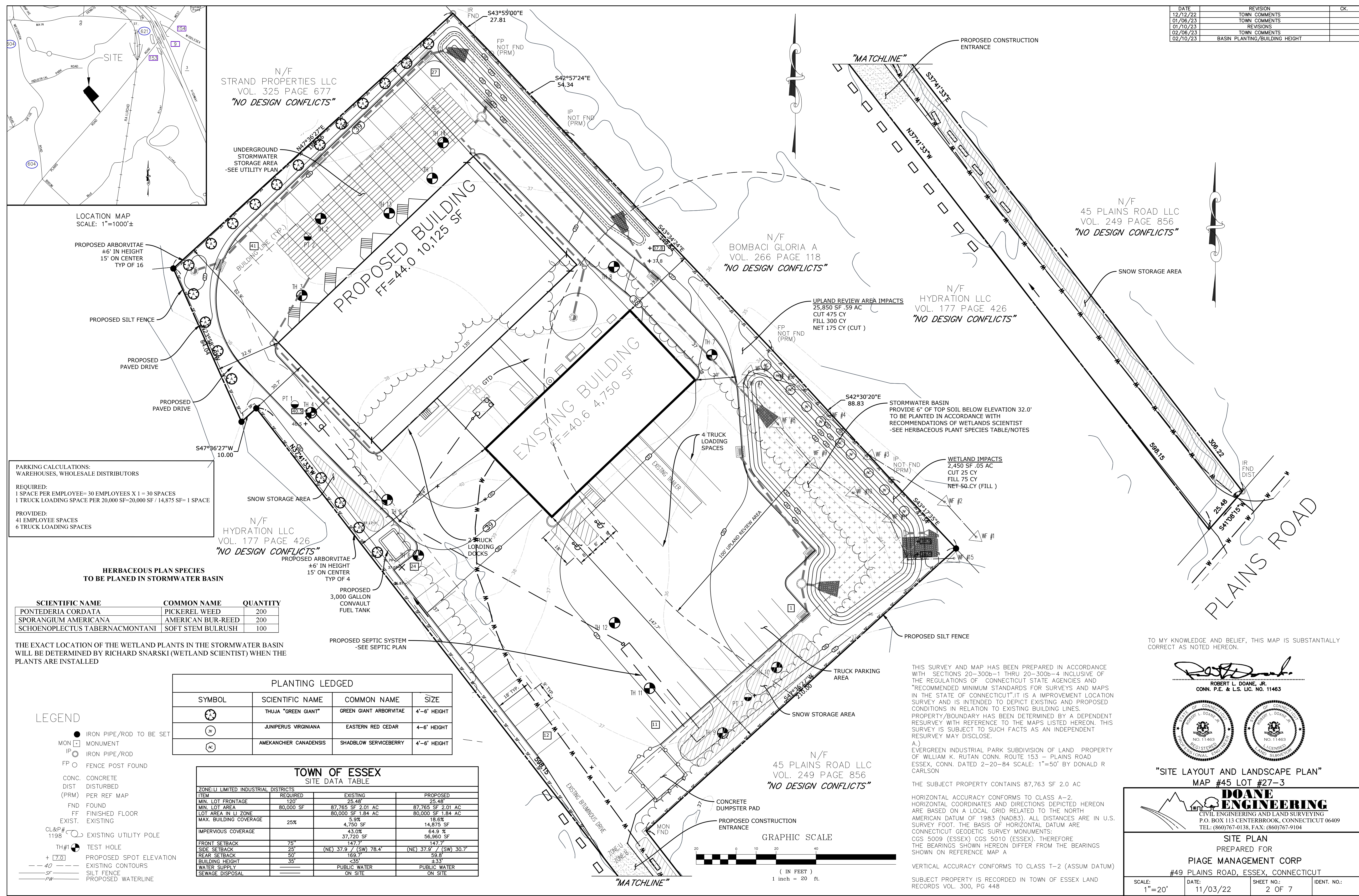

LOCATION MAP  
SCALE: 1"=1000'±

PROPOSED ARBORVITAE  
±6' IN HEIGHT  
15' ON CENTER  
TYP OF 16

PROPOSED SILT FENCE

PROPOSED PAVED DRIVE

PROPOSED PAVED DRIVE

PARKING CALCULATIONS:  
WAREHOUSES, WHOLESALE DISTRIBUTORS

REQUIRED:  
1 SPACE PER EMPLOYEE= 30 EMPLOYEES X 1 = 30 SPACES  
1 TRUCK LOADING SPACE PER 20,000 SF=20,000 SF / 14,875 SF= 1 SPACE

PROVIDED:  
41 EMPLOYEE SPACES  
6 TRUCK LOADING SPACES

**HERBACEOUS PLAN SPECIES  
TO BE PLANTED IN STORMWATER BASIN**

SCIENTIFIC NAME	COMMON NAME	QUANTITY
PONTEDERIA CORDATA	PICKEREL WEED	200
SPORANGIUM AMERICANA	AMERICAN BUR-REED	200
SCHOENOPLECTUS TABERNACMONTANI	SOFT STEM BULRUSH	100

THE EXACT LOCATION OF THE WETLAND PLANTS IN THE STORMWATER BASIN WILL BE DETERMINED BY RICHARD SNARSKI (WETLAND SCIENTIST) WHEN THE PLANTS ARE INSTALLED

**PLANTING LEDGED**

SYMBOL	SCIENTIFIC NAME	COMMON NAME	SIZE
●	THUJA "GREEN GIANT"	GREEN GIANT ARBORVITAE	4'-6" HEIGHT
○	JUNIPERUS VIRGINIANA	EASTERN RED CEDAR	4'-6" HEIGHT
○	AMEKANCHIER CANADENSIS	SHADBLOW SERVICEBERRY	4'-6" HEIGHT

- LEGEND**
- IRON PIPE/ROD TO BE SET
  - MON □ MONUMENT
  - IP ○ IRON PIPE/ROD
  - FP ○ FENCE POST FOUND
  - CONC. CONCRETE
  - DIST. DISTURBED
  - (PRM) PER REF MAP
  - FND FOUND
  - FF FINISHED FLOOR
  - EXIST. EXISTING
  - CL&P# 1198 ○ EXISTING UTILITY POLE
  - TH#1 ● TEST HOLE
  - + [7.0] PROPOSED SPOT ELEVATION
  - - - 40' EXISTING CONTOURS
  - - - SF SILT FENCE
  - - - FW PROPOSED WATERLINE

**TOWN OF ESSEX  
SITE DATA TABLE**

ITEM	REQUIRED	EXISTING	PROPOSED
MIN. LOT FRONTAGE	120'	25.48'	25.48'
MIN. LOT AREA	80,000 SF	87,765 SF 2.01 AC	87,765 SF 2.01 AC
LOT AREA IN LI ZONE		80,000 SF 1.84 AC	80,000 SF 1.84 AC
MAX. BUILDING COVERAGE	25%	5.9%	18.6%
IMPERVIOUS COVERAGE		43.0%	64.9%
FRONT SETBACK	75'	147.7'	147.7'
SIDE SETBACK	25'	(NE) 37.9' / (SW) 78.4'	(NE) 37.9' / (SW) 30.7'
REAR SETBACK	50'	169.7'	58.6'
BUILDING HEIGHT	35'	23.5'	23.5'
WATER SUPPLY		PUBLIC WATER	PUBLIC WATER
SEWAGE DISPOSAL		ON SITE	ON SITE

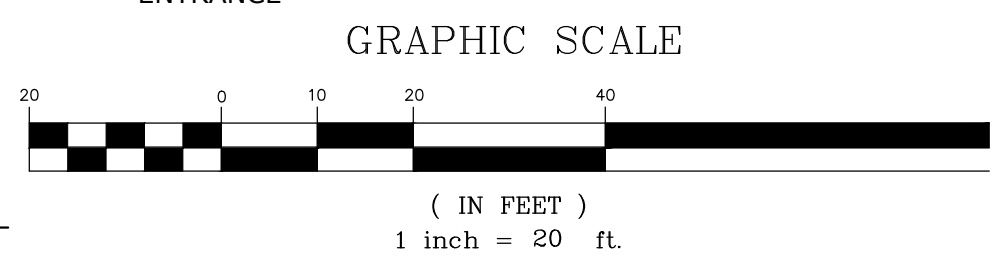

TO MY KNOWLEDGE AND BELIEF, THIS MAP IS SUBSTANTIALLY CORRECT AS NOTED HEREON.

*Robert L. Doane, Jr.*  
ROBERT L. DOANE, JR.  
CONN. P.E. & L.S. LIC. NO. 11463

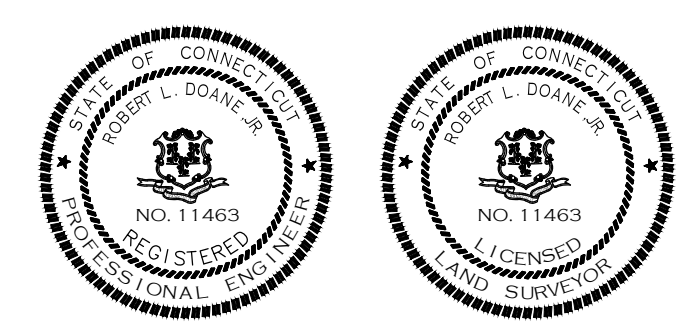

**"SITE LAYOUT AND LANDSCAPE PLAN"  
MAP #45 LOT #27-3**

**DOANE ENGINEERING**  
CIVIL ENGINEERING AND LAND SURVEYING  
P.O. BOX 113 CENTERBROOK, CONNECTICUT 06409  
TEL: (860)767-0138, FAX: (860)767-9104

SITE PLAN PREPARED FOR PIAGE MANAGEMENT CORP #49 PLAINS ROAD, ESSEX, CONNECTICUT			
SCALE: 1"=20'	DATE: 11/03/22	SHEET NO.: 2 OF 7	IDENT. NO.:

THIS SURVEY AND MAP HAS BEEN PREPARED IN ACCORDANCE WITH SECTIONS 20-300b-1 THRU 20-300b-4 INCLUSIVE OF THE REGULATIONS OF CONNECTICUT STATE AGENCIES AND "RECOMMENDED MINIMUM STANDARDS FOR SURVEYS AND MAPS IN THE STATE OF CONNECTICUT". IT IS AN IMPROVEMENT LOCATION SURVEY AND IS INTENDED TO DEPICT EXISTING AND PROPOSED CONDITIONS IN RELATION TO EXISTING BUILDING LINES. PROPERTY/BOUNDARY HAS BEEN DETERMINED BY A DEPENDENT RESURVEY WITH REFERENCE TO THE MAPS LISTED HEREON. THIS SURVEY IS SUBJECT TO SUCH FACTS AS AN INDEPENDENT RESURVEY MAY DISCLOSE.

A.) EVERGREEN INDUSTRIAL PARK SUBDIVISION OF LAND PROPERTY OF WILLIAM K. RUTAN CONN. ROUTE 153 - PLAINS ROAD ESSEX, CONN. DATED 2-20-84 SCALE: 1"=50' BY DONALD R CARLSON

THE SUBJECT PROPERTY CONTAINS 87,763 SF 2.0 AC

HORIZONTAL ACCURACY CONFORMS TO CLASS A-2. HORIZONTAL COORDINATES AND DIRECTIONS DEPICTED HEREON ARE BASED ON A LOCAL GRID RELATED TO THE NORTH AMERICAN DATUM OF 1983 (NAD83). ALL DISTANCES ARE IN U.S. SURVEY FOOT. THE BASIS OF HORIZONTAL DATUM ARE CONNECTICUT GEODETIC SURVEY MONUMENTS: CGS 5009 (ESSEX) CGS 5010 (ESSEX). THEREFORE THE BEARINGS SHOWN HEREON DIFFER FROM THE BEARINGS SHOWN ON REFERENCE MAP A

VERTICAL ACCURACY CONFORMS TO CLASS T-2 (ASSUM DATUM)

SUBJECT PROPERTY IS RECORDED IN TOWN OF ESSEX LAND RECORDS VOL. 300, PG 448

DATE	REVISION	CK.
12/12/22	TOWN COMMENTS	
01/06/23	TOWN COMMENTS	
01/10/23	REVISIONS	
02/06/23	TOWN COMMENTS	
02/10/23	BASIN PLANTING/BUILDING HEIGHT	

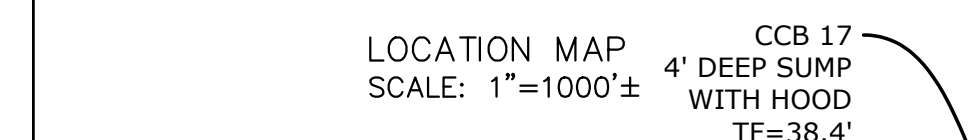
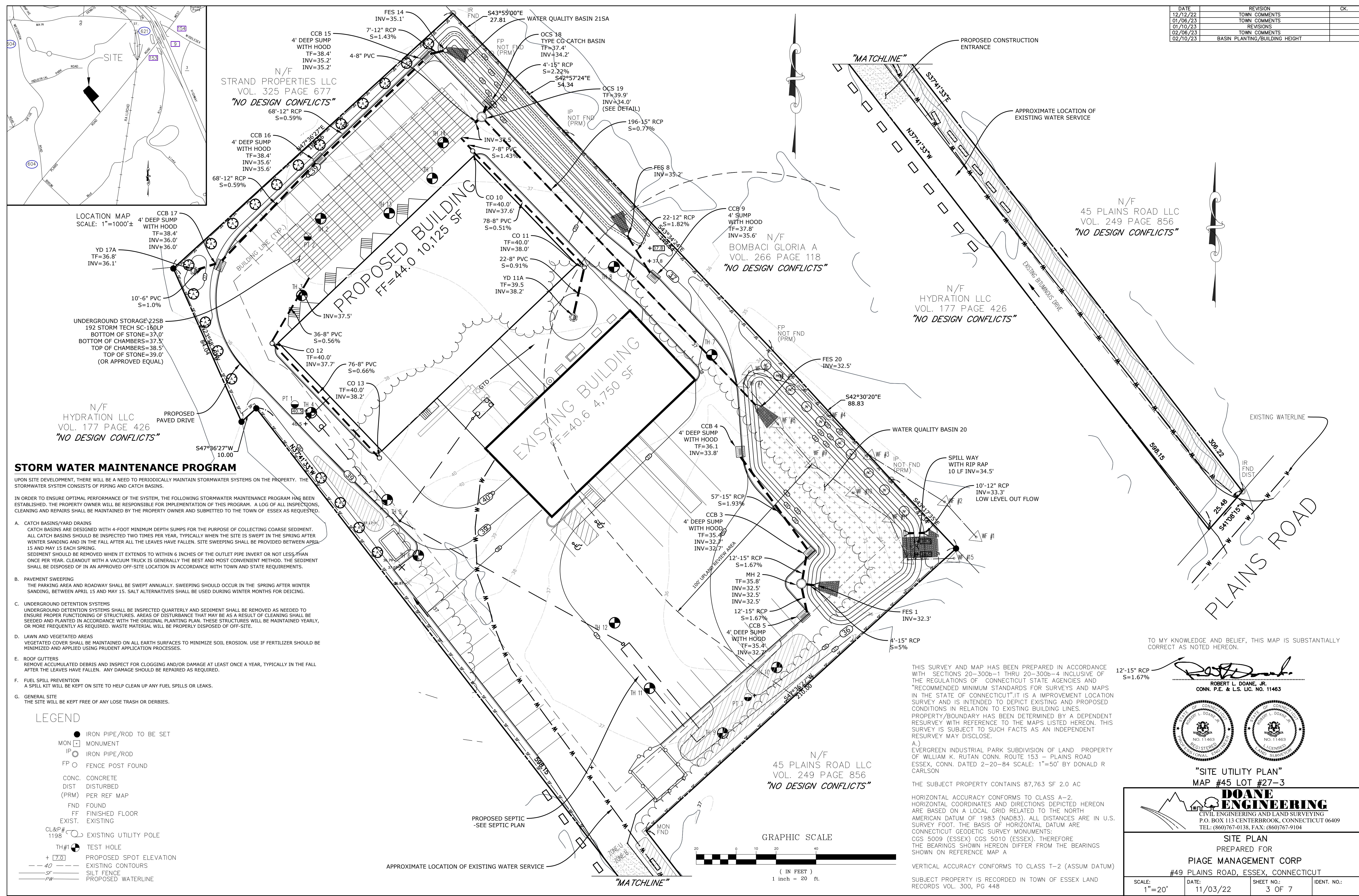

**STORM WATER MAINTENANCE PROGRAM**

UPON SITE DEVELOPMENT, THERE WILL BE A NEED TO PERIODICALLY MAINTAIN STORMWATER SYSTEMS ON THE PROPERTY. THE STORMWATER SYSTEM CONSISTS OF PIPING AND CATCH BASINS.

IN ORDER TO ENSURE OPTIMAL PERFORMANCE OF THE SYSTEM, THE FOLLOWING STORMWATER MAINTENANCE PROGRAM HAS BEEN ESTABLISHED. THE PROPERTY OWNER WILL BE RESPONSIBLE FOR IMPLEMENTATION OF THIS PROGRAM. A LOG OF ALL INSPECTIONS, CLEANING AND REPAIRS SHALL BE MAINTAINED BY THE PROPERTY OWNER AND SUBMITTED TO THE TOWN OF ESSEX AS REQUESTED.

- CATCH BASINS/YARD DRAINS**  
CATCH BASINS ARE DESIGNED WITH 4-FOOT MINIMUM DEPTH SUMPS FOR THE PURPOSE OF COLLECTING COARSE SEDIMENT. ALL CATCH BASINS SHOULD BE INSPECTED TWO TIMES PER YEAR, TYPICALLY WHEN THE SITE IS SWEEPED IN THE SPRING AFTER WINTER SANDING AND IN THE FALL AFTER ALL THE LEAVES HAVE FALLEN. SITE SWEEPING SHALL BE PROVIDED BETWEEN APRIL 15 AND MAY 15 EACH SPRING. SEDIMENT SHOULD BE REMOVED WHEN IT EXTENDS TO WITHIN 6 INCHES OF THE OUTLET PIPE INVERT OR NOT LESS THAN ONCE PER YEAR. CLEANOUT WITH A VACUUM TRUCK IS GENERALLY THE BEST AND MOST CONVENIENT METHOD. THE SEDIMENT SHALL BE DISPOSED OF IN AN APPROVED OFF-SITE LOCATION IN ACCORDANCE WITH TOWN AND STATE REQUIREMENTS.
- PAVEMENT SWEEPING**  
THE PARKING AREA AND ROADWAY SHALL BE SWEEPED ANNUALLY. SWEEPING SHOULD OCCUR IN THE SPRING AFTER WINTER SANDING, BETWEEN APRIL 15 AND MAY 15. SALT ALTERNATIVES SHALL BE USED DURING WINTER MONTHS FOR DEICING.
- UNDERGROUND DETENTION SYSTEMS**  
UNDERGROUND DETENTION SYSTEMS SHALL BE INSPECTED QUARTERLY AND SEDIMENT SHALL BE REMOVED AS NEEDED TO ENSURE PROPER FUNCTIONING OF STRUCTURES. AREAS OF DISTURBANCE THAT MAY BE AS A RESULT OF CLEANING SHALL BE SEEDED AND PLANTED IN ACCORDANCE WITH THE ORIGINAL PLANTING PLAN. THESE STRUCTURES WILL BE MAINTAINED YEARLY, OR MORE FREQUENTLY AS REQUIRED. WASTE MATERIAL WILL BE PROPERLY DISPOSED OF OFF-SITE.
- LAWN AND VEGETATED AREAS**  
VEGETATED COVER SHALL BE MAINTAINED ON ALL EARTH SURFACES TO MINIMIZE SOIL EROSION. USE IF FERTILIZER SHOULD BE MINIMIZED AND APPLIED USING PRUDENT APPLICATION PROCESSES.
- ROOF GUTTERS**  
REMOVE ACCUMULATED DEBRIS AND INSPECT FOR CLOGGING AND/OR DAMAGE AT LEAST ONCE A YEAR, TYPICALLY IN THE FALL AFTER THE LEAVES HAVE FALLEN. ANY DAMAGE SHOULD BE REPAIRED AS REQUIRED.
- FUEL SPILL PREVENTION**  
A SPILL KIT WILL BE KEPT ON SITE TO HELP CLEAN UP ANY FUEL SPILLS OR LEAKS.
- GENERAL SITE**  
THE SITE WILL BE KEPT FREE OF ANY LOSE TRASH OR DERBIES.

- LEGEND**
- IRON PIPE/ROD TO BE SET
  - MON □ MONUMENT
  - IP ○ IRON PIPE/ROD
  - FP ○ FENCE POST FOUND
  - CONC. CONCRETE
  - DIST. DISTURBED
  - (PRM) PER REF MAP
  - FND FOUND
  - FF FINISHED FLOOR
  - EXIST. EXISTING
  - CL&P# 1198 ○ EXISTING UTILITY POLE
  - TH#1 ● TEST HOLE
  - + [7.0] PROPOSED SPOT ELEVATION
  - - - 40 - - - EXISTING CONTOURS
  - - - SF - - - SILT FENCE
  - - - PW - - - PROPOSED WATERLINE

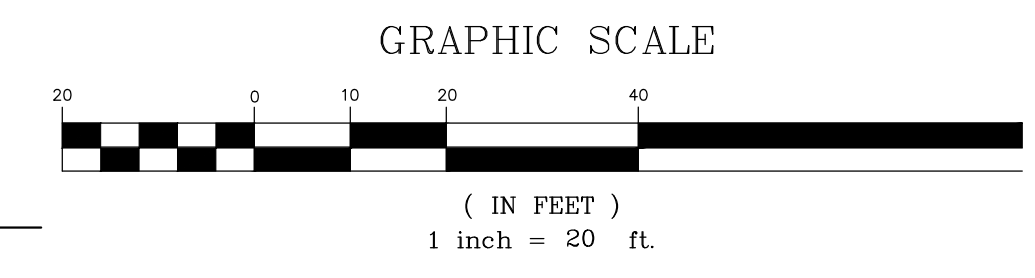

TO MY KNOWLEDGE AND BELIEF, THIS MAP IS SUBSTANTIALLY CORRECT AS NOTED HEREON.

*Robert L. Doane, Jr.*  
**ROBERT L. DOANE, JR.**  
 CONN. P.E. & L.S. LIC. NO. 11463

NO. 11463  
 REGISTERED PROFESSIONAL ENGINEER  
 LICENSED LAND SURVEYOR

NO. 11463  
 REGISTERED PROFESSIONAL ENGINEER  
 LICENSED LAND SURVEYOR

**"SITE UTILITY PLAN"**  
 MAP #45 LOT #27-3

**DOANE ENGINEERING**  
 CIVIL ENGINEERING AND LAND SURVEYING  
 P.O. BOX 113 CENTERBROOK, CONNECTICUT 06409  
 TEL: (860)767-0138, FAX: (860)767-9104

**SITE PLAN**  
 PREPARED FOR  
**PIAGE MANAGEMENT CORP**  
 #49 PLAINS ROAD, ESSEX, CONNECTICUT

SCALE: 1"=20'  
 DATE: 11/03/22  
 SHEET NO.: 3 OF 7  
 IDENT. NO.:

THIS SURVEY AND MAP HAS BEEN PREPARED IN ACCORDANCE WITH SECTIONS 20-300b-1 THRU 20-300b-4 INCLUSIVE OF THE REGULATIONS OF CONNECTICUT STATE AGENCIES AND "RECOMMENDED MINIMUM STANDARDS FOR SURVEYS AND MAPS IN THE STATE OF CONNECTICUT". IT IS AN IMPROVEMENT LOCATION SURVEY AND IS INTENDED TO DEPICT EXISTING AND PROPOSED CONDITIONS IN RELATION TO EXISTING BUILDING LINES. PROPERTY/BOUNDARY HAS BEEN DETERMINED BY A DEPENDENT RESURVEY WITH REFERENCE TO THE MAPS LISTED HEREON. THIS SURVEY IS SUBJECT TO SUCH FACTS AS AN INDEPENDENT RESURVEY MAY DISCLOSE.

A.) EVERGREEN INDUSTRIAL PARK SUBDIVISION OF LAND PROPERTY OF WILLIAM K. RUTAN CONN. ROUTE 153 - PLAINS ROAD ESSEX, CONN. DATED 2-20-84 SCALE: 1"=50' BY DONALD R CARLSON

THE SUBJECT PROPERTY CONTAINS 87,763 SF 2.0 AC

HORIZONTAL ACCURACY CONFORMS TO CLASS A-2. HORIZONTAL COORDINATES AND DIRECTIONS DEPICTED HEREON ARE BASED ON A LOCAL GRID RELATED TO THE NORTH AMERICAN DATUM OF 1983 (NAD83). ALL DISTANCES ARE IN U.S. SURVEY FOOT. THE BASIS OF HORIZONTAL DATUM ARE CONNECTICUT GEODETIC SURVEY MONUMENTS: CGS 5009 (ESSEX) CGS 5010 (ESSEX). THEREFORE THE BEARINGS SHOWN HEREON DIFFER FROM THE BEARINGS SHOWN ON REFERENCE MAP A

VERTICAL ACCURACY CONFORMS TO CLASS T-2 (ASSUM DATUM)

SUBJECT PROPERTY IS RECORDED IN TOWN OF ESSEX LAND RECORDS VOL. 300, PG 448

N/F STRAND PROPERTIES LLC VOL. 325 PAGE 677 "NO DESIGN CONFLICTS"

CCB 15 4' DEEP SUMP WITH HOOD TF=38.4' INV=35.2' INV=35.2' 7'-12" RCP S=1.43% 4-8" PVC

CCB 16 4' DEEP SUMP WITH HOOD TF=38.4' INV=35.6' INV=35.6' 68"-12" RCP S=0.59%

CCB 17 4' DEEP SUMP WITH HOOD TF=36.0' INV=36.0' INV=36.0' 10'-6" PVC S=1.0%

UNDERGROUND STORAGE 22SB 192 STORM TECH SC-160LP BOTTOM OF STONE=37.0' BOTTOM OF CHAMBERS=37.5' TOP OF CHAMBERS=38.5' TOP OF STONE=39.0' (OR APPROVED EQUAL)

N/F HYDRATION LLC VOL. 177 PAGE 426 "NO DESIGN CONFLICTS"

PROPOSED BUILDING FF=44.0 10,125 SF

EXISTING BUILDING FF=40.6 4,750 SF

N/F BOMBACI GLORIA A VOL. 266 PAGE 118 "NO DESIGN CONFLICTS"

N/F HYDRATION LLC VOL. 177 PAGE 426 "NO DESIGN CONFLICTS"

N/F 45 PLAINS ROAD LLC VOL. 249 PAGE 856 "NO DESIGN CONFLICTS"

N/F 45 PLAINS ROAD LLC VOL. 249 PAGE 856 "NO DESIGN CONFLICTS"

PLAINS ROAD

PROPOSED SEPTIC -SEE SEPTIC PLAN

APPROXIMATE LOCATION OF EXISTING WATER SERVICE

"MATCHLINE"

PROPOSED CONSTRUCTION ENTRANCE

APPROXIMATE LOCATION OF EXISTING WATER SERVICE

"MATCHLINE"



EXISTING WATERLINE

WATER QUALITY BASIN 20

SPILL WAY WITH RIP RAP 10 LF INV=34.5'

10'-12" RCP INV=33.3' LOW LEVEL OUT FLOW

CCB 3 4' DEEP SUMP WITH HOOD TF=35.4' INV=32.7' INV=32.7' 12'-15" RCP S=1.67% 4-8" PVC

CCB 4 4' DEEP SUMP WITH HOOD TF=36.1' INV=33.8' INV=33.8' 12'-15" RCP S=1.67% 4-8" PVC

CCB 5 4' DEEP SUMP WITH HOOD TF=35.4' INV=32.7' INV=32.7' 12'-15" RCP S=1.67% 4-8" PVC

CCB 9 4' SUMP WITH HOOD TF=37.8' INV=35.6' INV=35.6' 22-12" RCP S=1.82%

CCB 10 TF=40.0' INV=37.6' INV=37.6' 78-8" PVC S=0.51%

CCB 11 TF=40.0' INV=38.0' INV=38.0' 22-8" PVC S=0.91%

CCB 12 TF=40.0' INV=37.7' INV=37.7' 76-8" PVC S=0.66%

CCB 13 TF=40.0' INV=38.2' INV=38.2' 76-8" PVC S=0.66%

OCS 18 TYPE CO-CATCH BASIN TF=37.4' INV=34.2' INV=34.2' 4'-15" RCP S=2.22%

OCS 19 TF=39.9' INV=34.0' INV=34.0' 196-15" RCP S=0.77%

FES 8 INV=35.2' INV=35.2' 7-8" PVC S=1.43%

FES 1 INV=32.3' INV=32.3' 4'-15" RCP S=5%

FES 20 INV=32.5' INV=32.5' 57'-15" RCP S=1.93%

FES 1 INV=32.3' INV=32.3' 4'-15" RCP S=5%

FES 1 INV=32.3' INV=32.3' 4'-15" RCP S=5%

FES 1 INV=32.3' INV=32.3' 4'-15" RCP S=5%

FES 1 INV=32.3' INV=32.3' 4'-15" RCP S=5%

FES 1 INV=32.3' INV=32.3' 4'-15" RCP S=5%

FES 1 INV=32.3' INV=32.3' 4'-15" RCP S=5%

FES 1 INV=32.3' INV=32.3' 4'-15" RCP S=5%

FES 1 INV=32.3' INV=32.3' 4'-15" RCP S=5%

FES 1 INV=32.3' INV=32.3' 4'-15" RCP S=5%

FES 1 INV=32.3' INV=32.3' 4'-15" RCP S=5%

FES 1 INV=32.3' INV=32.3' 4'-15" RCP S=5%

FES 1 INV=32.3' INV=32.3' 4'-15" RCP S=5%

DATE	REVISION	CK.
12/12/22	TOWN COMMENTS	
01/06/23	TOWN COMMENTS	
01/10/23	REVISIONS	
02/06/23	TOWN COMMENTS	
02/09/23	BASIN PLANTING	

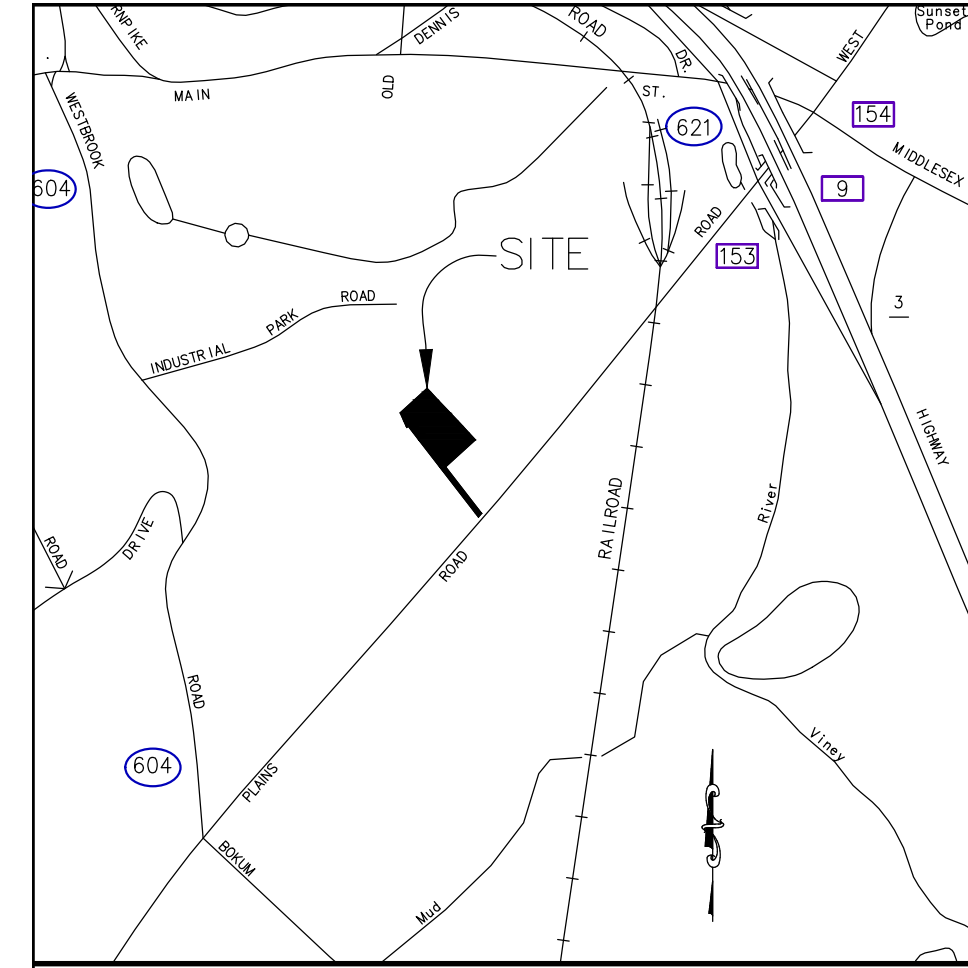

N/F  
STRAND PROPERTIES LLC  
VOL. 325 PAGE 677  
"NO DESIGN CONFLICTS"

N/F  
BOMBACI GLORIA A  
VOL. 266 PAGE 118  
"NO DESIGN CONFLICTS"

N/F  
HYDRATION LLC  
VOL. 177 PAGE 426  
"NO DESIGN CONFLICTS"

N/F  
45 PLAINS ROAD LLC  
VOL. 249 PAGE 856  
"NO DESIGN CONFLICTS"

N/F  
HYDRATION LLC  
VOL. 177 PAGE 426  
"NO DESIGN CONFLICTS"

N/F  
45 PLAINS ROAD LLC  
VOL. 249 PAGE 856  
"NO DESIGN CONFLICTS"

SANITARY SYSTEM DESIGN CRITERIA:  
DESIGN FLOW = 450 GPD (BASED ON WATER USAGE DATA)  
PERCOLATION RATE = 1.0-10.0 MIN/IN  
APPLICATION RATE = 1.5 GAL/SF/DAY  
REQUIRED EFFECTIVE LEACHING AREA = 450/1.5 = 300 SF  
PROVIDED 1 - 60 LF ROWS OF GST 6212  
EFFECTIVE LEACHING AREA PROVIDED = 1 X 60 LF X 10.0 LF/SF = 600 SF  
MINIMUM LEACHING SYSTEM SPREAD (MLSS)  
DEPTH TO RESTRICTIVE LAYER = 38 INCHES  
(BASED ON GROUND WATER MONITING TP-10)  
SLOPE = 1.0 %  
HF = 36  
FF = 450/300 = 1.5  
PF = 1  
MLSS REQUIRED = 36 X 1.5 X 1 = 54 LF  
MLSS PROVIDED = 1 ROW X 60 = 60 LF

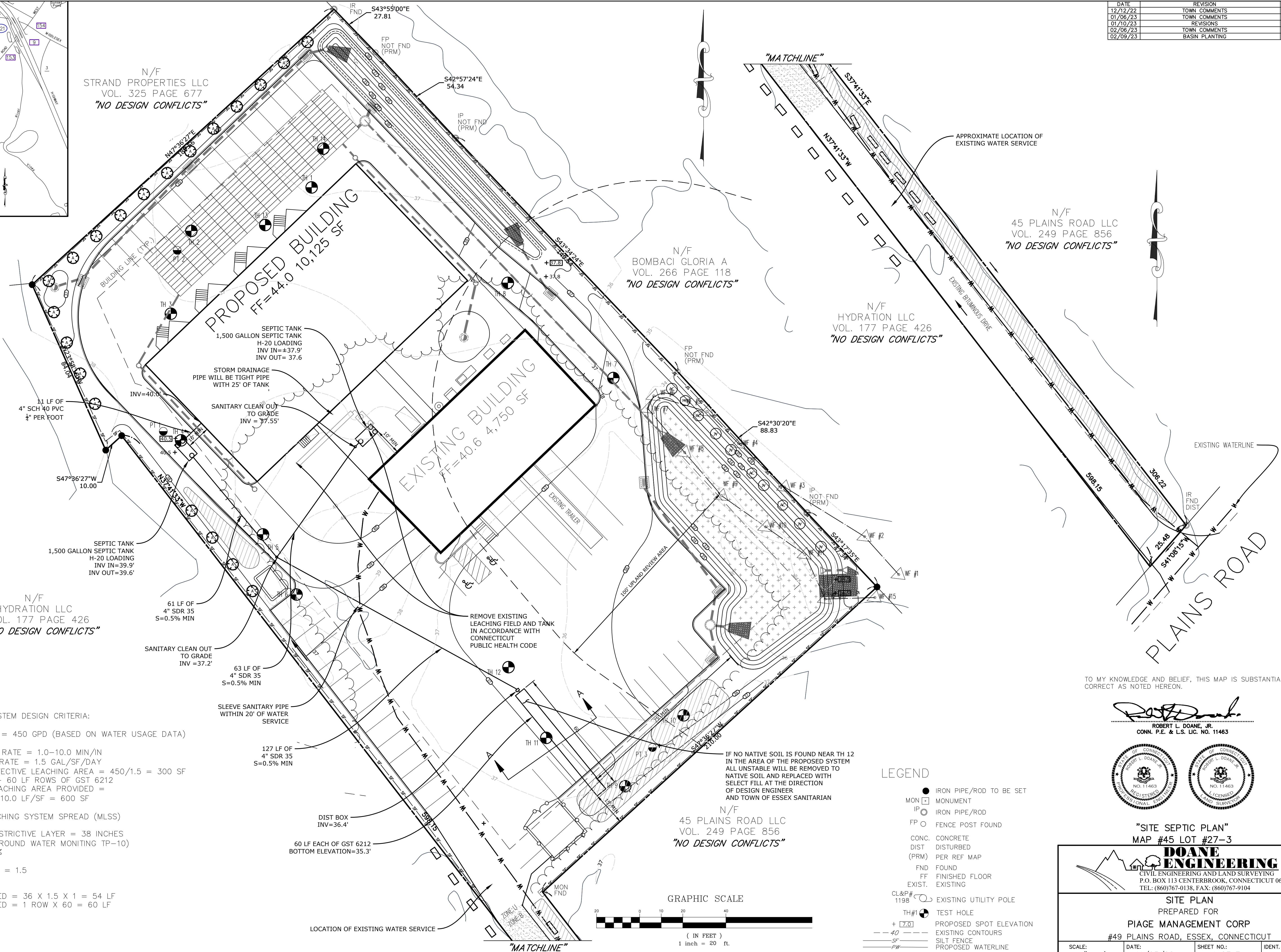

TO MY KNOWLEDGE AND BELIEF, THIS MAP IS SUBSTANTIALLY CORRECT AS NOTED HEREON.

*Robert L. Doane, Jr.*  
ROBERT L. DOANE, JR.  
CONN. P.E. & L.S. LIC. NO. 11463

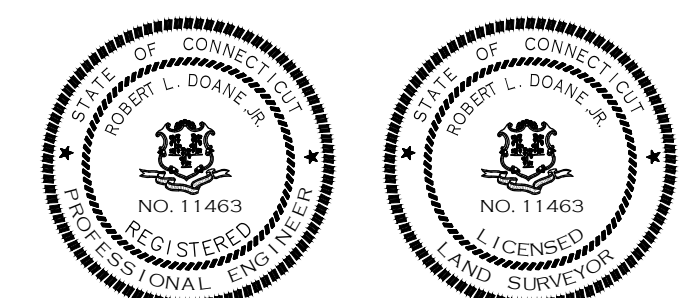

LEGEND

- IRON PIPE/ROD TO BE SET
- MON □ MONUMENT
- IP ○ IRON PIPE/ROD
- FP ○ FENCE POST FOUND
- CONC. CONCRETE
- DIST DISTURBED
- (PRM) PER REF MAP
- FND FOUND
- FF FINISHED FLOOR
- EXIST. EXISTING
- CL&P# 1198 ○ EXISTING UTILITY POLE
- TH#1 ● TEST HOLE
- + [7.0] PROPOSED SPOT ELEVATION
- 40 - - - - EXISTING CONTOURS
- SF - - - - SILT FENCE
- PW - - - - PROPOSED WATERLINE

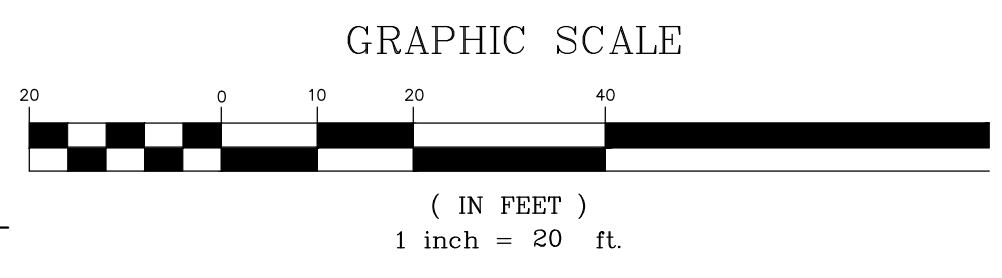

"SITE SEPTIC PLAN"  
MAP #45 LOT #27-3

**DOANE ENGINEERING**  
CIVIL ENGINEERING AND LAND SURVEYING  
P.O. BOX 113 CENTERBROOK, CONNECTICUT 06409  
TEL: (860)767-0138, FAX: (860)767-9104

SITE PLAN  
PREPARED FOR  
PIAGE MANAGEMENT CORP  
#49 PLAINS ROAD, ESSEX, CONNECTICUT

SCALE: 1"=20'	DATE: 11/03/22	SHEET NO.: 4 OF 7	IDENT. NO.:
------------------	-------------------	----------------------	-------------

	DATE	REVISION	CK.
	12/12/22	TOWN COMMENTS	
	01/06/23	TOWN COMMENTS	
	01/10/23	REVISIONS	
	02/06/23	TOWN COMMENTS	
	02/10/23	BASIN PLANTING/BUILDING HEIGHT	

**ACCEPTABLE FILL MATERIALS: STORMTECH SC-160LP CHAMBER SYSTEMS**

MATERIAL LOCATION	DESCRIPTION	AASHTO MATERIAL CLASSIFICATIONS	COMPACTION / DENSITY REQUIREMENT
D	FINAL FILL: FILL MATERIAL FOR LAYER 'D' STARTS FROM THE TOP OF THE 'C' LAYER TO THE BOTTOM OF FLEXIBLE PAVEMENT OR UNPAVED FINISHED GRADE ABOVE. NOTE THAT PAVEMENT SUBBASE MAY BE PART OF THE 'D' LAYER.	ANY SOIL/ROCK MATERIALS, NATIVE SOILS, OR PER ENGINEER'S PLANS. CHECK PLANS FOR PAVEMENT SUBGRADE REQUIREMENTS.	PREPARE PER SITE DESIGN ENGINEER'S PLANS. PAVED INSTALLATIONS MAY HAVE STRINGENT MATERIAL AND PREPARATION REQUIREMENTS.
C	INITIAL FILL: FILL MATERIAL FOR LAYER 'C' STARTS FROM THE TOP OF THE EMBEDMENT STONE ('B' LAYER) TO 14" (355 mm) ABOVE THE TOP OF THE CHAMBER. NOTE THAT PAVEMENT SUBBASE MAY BE A PART OF THE 'C' LAYER.	GRANULAR WELL-GRADED SOIL/AGGREGATE MIXTURES, <35% FINES OR PROCESSED AGGREGATE. MOST PAVEMENT SUBBASE MATERIALS CAN BE USED IN LIEU OF THIS LAYER.	BEGIN COMPACTIONS AFTER 12" (300 mm) OF MATERIAL OVER THE CHAMBERS IS REACHED. COMPACT ADDITIONAL LAYERS IN 6" (150 mm) MAX LIFTS TO A MIN. 95% PROCTOR DENSITY FOR WELL GRADED MATERIAL AND 95% RELATIVE DENSITY FOR PROCESSED AGGREGATE MATERIALS. ROLLER GROSS VEHICLE WEIGHT NOT TO EXCEED 12,000 lbs (53 kN). DYNAMIC FORCE NOT TO EXCEED 20,000 lbs (89 kN).
B	EMBODIMENT STONE: FILL SURROUNDING THE CHAMBERS FROM THE FOUNDATION STONE ('A' LAYER) TO THE 'C' LAYER ABOVE.	CLEAN, CRUSHED, ANGULAR STONE	NO COMPACTION REQUIRED.
A	FOUNDATION STONE: FILL BELOW CHAMBERS FROM THE SUBGRADE UP TO THE FOOT (BOTTOM) OF THE CHAMBER.	CLEAN, CRUSHED, ANGULAR STONE	PLATE COMPACT OR ROLL TO ACHIEVE A FLAT SURFACE. <sup>2,3</sup>

PLEASE NOTE:  
1. THE LISTED AASHTO DESIGNATIONS ARE FOR GRADATIONS ONLY. THE STONE MUST ALSO BE CLEAN, CRUSHED, ANGULAR. FOR EXAMPLE, A SPECIFICATION FOR #4 STONE WOULD STATE: "CLEAN, CRUSHED, ANGULAR NO. 4 (AASHTO M43) STONE".  
2. STORMTECH COMPACTION REQUIREMENTS ARE MET FOR 'A' LOCATION MATERIALS WHEN PLACED AND COMPACTED IN 6" (150 mm) MAX LIFTS USING TWO FULL COVERAGES WITH A VIBRATORY COMPACTOR.  
3. WHERE INFILTRATION SURFACES MAY BE COMPROMISED BY COMPACTION, FOR STANDARD DESIGN LOAD CONDITIONS, A FLAT SURFACE MAY BE ACHIEVED BY RAKING OR DRAGGING WITHOUT COMPACTION EQUIPMENT. FOR SPECIAL LOAD DESIGNS, CONTACT STORMTECH FOR COMPACTION REQUIREMENTS.  
4. ONCE LAYER 'C' IS PLACED, ANY SOIL/MATERIAL CAN BE PLACED IN LAYER 'D' UP TO THE FINISHED GRADE. MOST PAVEMENT SUBBASE SOILS CAN BE USED TO REPLACE THE MATERIAL REQUIREMENTS OF LAYER 'C' OR 'D' AT THE SITE DESIGN ENGINEER'S DISCRETION.

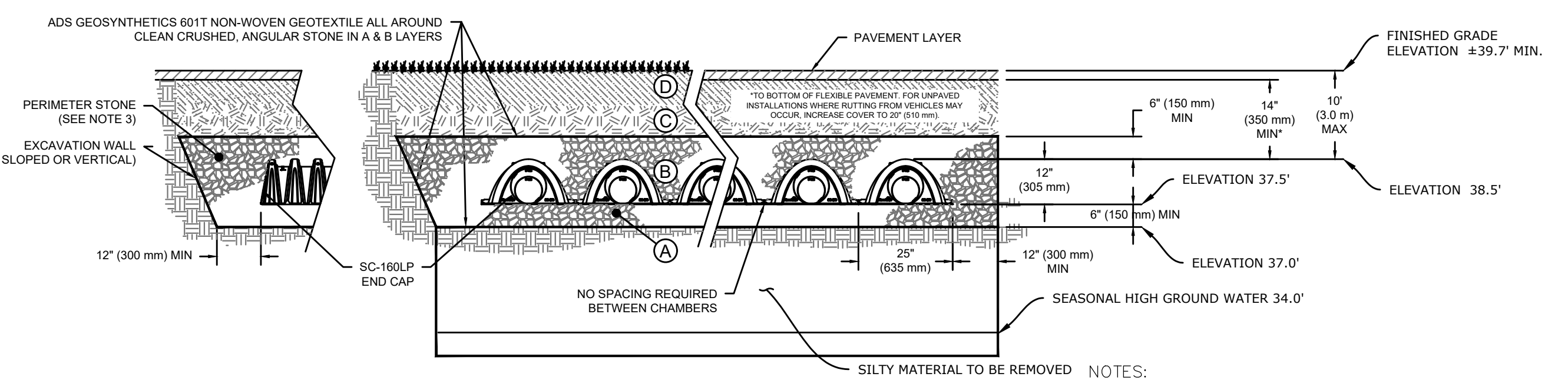

- NOTES:**
- CHAMBERS SHALL MEET THE REQUIREMENTS OF ASTM F2418, "STANDARD SPECIFICATION FOR POLYPROPYLENE (PP) CORRUGATED WALL STORMWATER COLLECTION CHAMBERS".
  - CHAMBERS SHALL BE DESIGNED, TESTED AND ALLOWABLE LOAD CONFIGURATIONS DETERMINED IN ACCORDANCE WITH ASTM F2787, "STANDARD PRACTICE FOR STRUCTURAL DESIGN OF THERMOPLASTIC CORRUGATED WALL STORMWATER COLLECTION CHAMBERS". LOAD CONFIGURATIONS SHALL INCLUDE: 1) INSTANTANEOUS (<1 MIN) AASHTO DESIGN TRUCK LIVE LOAD ON MINIMUM COVER 2) MAXIMUM PERMANENT (75-YR) COVER LOAD AND 3) ALLOWABLE COVER WITH PARKED (1-WEEK) AASHTO DESIGN TRUCK.
  - PERIMETER STONE MUST BE EXTENDED HORIZONTALLY TO THE EXCAVATION WALL FOR BOTH VERTICAL AND SLOPED EXCAVATION WALLS.
  - REQUIREMENTS FOR HANDLING AND INSTALLATION:
    - TO MAINTAIN THE WIDTH OF CHAMBERS DURING SHIPPING AND HANDLING, CHAMBERS SHALL HAVE INTEGRAL, INTERLOCKING STACKING LUGS
    - TO ENSURE A SECURE JOINT DURING INSTALLATION AND BACKFILL, THE HEIGHT OF THE CHAMBER JOINT SHALL NOT BE LESS THAN 1.5"
    - TO ENSURE THE INTEGRITY OF THE ARCH SHAPE DURING INSTALLATION, a) THE ARCH STIFFNESS CONSTANT AS DEFINED IN SECTION 6.2.8 OF ASTM F2418 SHALL BE GREATER THAN OR EQUAL TO 400 LBS/FT<sup>3</sup> AND b) TO RESIST CHAMBER DEFORMATION DURING INSTALLATION AT ELEVATED TEMPERATURES (ABOVE 73° F / 23° C), CHAMBERS SHALL BE PRODUCED FROM REFLECTIVE GOLD OR YELLOW COLORS.
- NOTES:  
1. SILTY SOIL FOUND BELOW THE AREA OF THE PROPOSED INFILTRATION SYSTEM TO BE REMOVED AND REPLACED WITH SUITABLE FILL AT THE DISCRETION OF THE DESIGN ENGINEER. REPLACEMENT MATERIAL WILL HAVE A MINIMUM INFILTRATION RATE OF 4 INCHES PER HOUR.  
2. SILTY SOIL TO BE REMOVED IS FROM APPROXIMATELY ELEVATION 36.0'-33.0'.  
3. SEASONAL HIGH GROUND WATER IS FOUND AT ELEVATION 34.0' BASED ON TEST PITS AND GROUND WATER MONITORING

**UNDERGROUND DETENTION SYSTEM 22SB**  
NOT TO SCALE

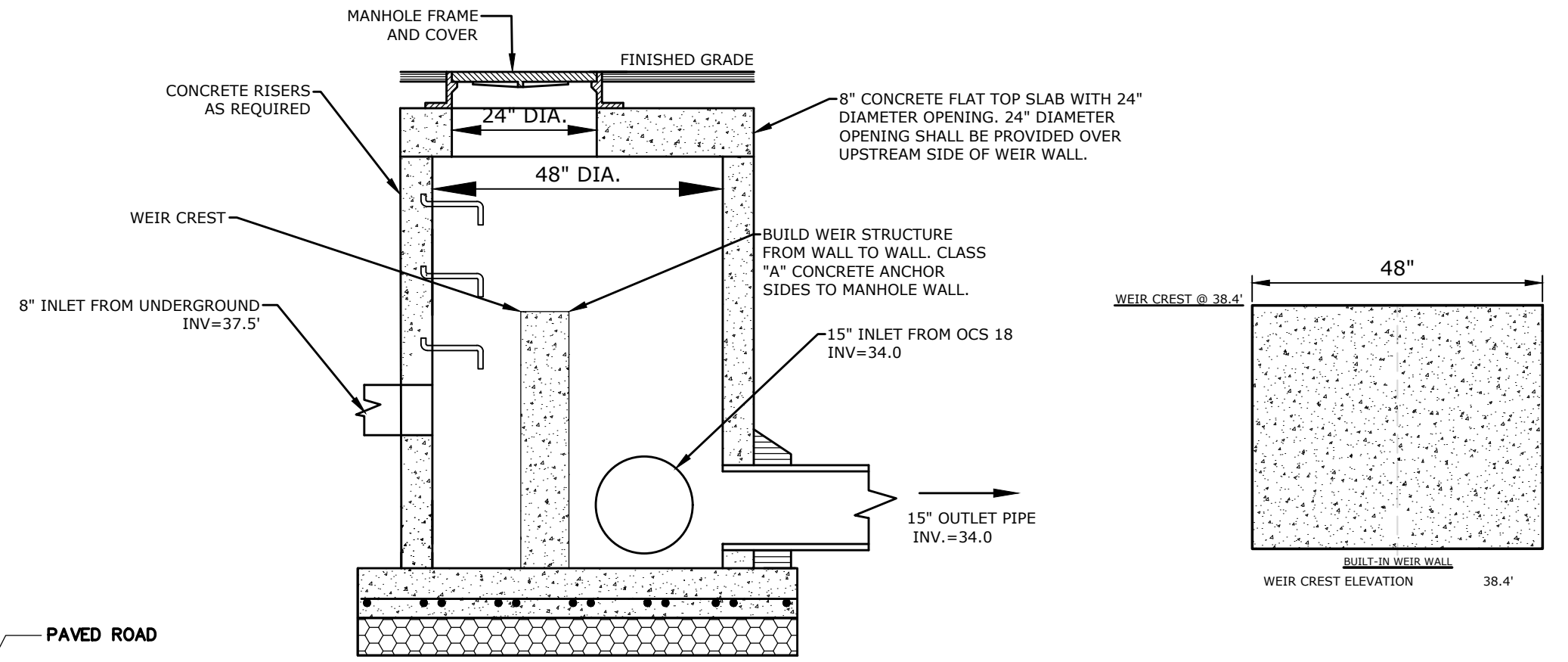

NOTES:  
THIS DETAIL REPRESENTS A MODIFICATION OF A STANDARD STORM MANHOLE FOR USE IN CONTROLLING THE DISCHARGE FROM THE DETENTION AREA. SEE THE MANHOLE DETAIL FOR STANDARD DIMENSIONS AND NOTES.

**OUTLET CONTROL STRUCTURE FOR UNDERGROUND DETENTION SYSTEM 22SB**  
NOT TO SCALE

- I. GENERAL:**
- IT IS ANTICIPATED THAT CONSTRUCTION WILL OCCUR IN SPRING 2023 WITH PERMANENT SEEDING ACCOMPLISHED BETWEEN AUG. 15TH AND OCT. 15TH OF 2023.
  - IT IS ANTICIPATED THAT THE SITE WILL BE STABILIZED BY OCT. 15, 2023.
  - THE CONTRACTOR, TO BE DETERMINED, WILL BE RESPONSIBLE FOR EROSION AND SEDIMENT CONTROL.
  - ALL CONSTRUCTION ACTIVITIES SHALL BE PERFORMED TO MINIMIZE EROSION AND SEDIMENTATION IN ACCORDANCE WITH "2002 CONNECTICUT GUIDELINES FOR SOIL EROSION AND SEDIMENT CONTROL".
  - IF DURING CONSTRUCTION, THE ENFORCEMENT OFFICER OR ENGINEER DEEMS ADDITIONAL EROSION CONTROL NECESSARY, IT SHALL BE ADDED. THE CONTRACTOR SHALL MAKE ADDITIONAL SUPPLIES READILY AVAILABLE.
  - ONLY THE AREAS WHICH ARE ACTIVELY BEING DEVELOPED SHOULD BE EXPOSED. ALL OTHER AREAS SHOULD BE HEAVILY MULCHED, HAVE NATURAL VEGETATION PRESERVED OR HAVE A GOOD COVER OF TEMPORARY OR PERMANENT VEGETATION ESTABLISHED.
  - DISTURBED AREAS SHALL BE STABILIZED AS QUICKLY AS POSSIBLE.
  - ALL TEMPORARY EROSION AND SEDIMENTATION CONTROLS MUST REMAIN IN PLACE AND BE MAINTAINED UNTIL PERMANENT STABILIZATION IS ACCOMPLISHED.
- II. INSPECTION:**
- INSPECTION SHOULD BE MADE OF ALL EROSION AND SEDIMENTATION CONTROL MEASURES A MINIMUM OF ONCE A WEEK AND AFTER EACH RAINFALL EVENT.
- III. CONSTRUCTION SEQUENCE:**
- THE SEQUENCE FOR THE INSTALLATION OF EROSION AND SEDIMENT CONTROL, SITE IMPROVEMENTS, GRADING AND SITE STABILIZATION SHALL BE AS FOLLOWS:
    - NOTIFY "CALL BEFORE YOU DIG" (1-800-922-4455) PRIOR TO CONSTRUCTION.
    - STAKE CLEARING LIMITS AND REVIEW WITH TOWN ENFORCEMENT OFFICER TOWN ENGINEER, PROJECT ENGINEER AND CONTRACTOR AT PRE-CONSTRUCTION CONFERENCE
    - CONSTRUCT TEMPORARY CONSTRUCTION PAD AT THE DRIVEWAY ENTRANCE UNTIL THE PROPOSED ENTRANCE IS ESTABLISHED
    - CLEAR TREES AND BRUSH FROM AREA TO BE GRADED.
    - INSTALL SILT FENCE BARRIER WHERE SHOWN ON THE DRAWINGS AND AS INDICATED IN THE DETAIL. BACK SILT FENCE BARRIER WITH HAY BALES WHERE SHOWN ON THE DRAWINGS AND AS INDICATED IN THE DETAIL.
    - FIELD STAKE BUILDING AND AREAS TO BE PAVED.
    - REMOVE ALL STUMPS, TOPSOIL AND DELETERIOUS MATERIALS FROM THE AREA TO BE DEVELOPED.
    - STOCKPILE TOPSOIL FOR REUSE. TOPSOIL SHALL BE STOCKPILED IN SUCH A MANNER THAT NATURAL DRAINAGE IS NOT OBSTRUCTED AND NO OFF-SITE SEDIMENT DAMAGE SHALL RESULT.
      - SIDE SLOPES OF THE STOCKPILE SHALL NOT EXCEED 2 TO 1.
      - SURROUND STOCKPILE WITH SILT FENCE.
    - TEMPORARY SEEDING OF STOCKPILE SHALL BE COMPLETED WITHIN 15 DAYS OF ITS FORMATION IN ACCORDANCE WITH THE MEASURES OUTLINED IN ITEM V.
    - GRADE SITE TO THE LINES AND ELEVATIONS SHOWN ON THE PLANS AND DETAILS
    - HAVE LAND SURVEYOR STAKE AND OFF-SET THE FOUNDATION.
    - CONTRACTOR SHALL EXCAVATE AND POUR FOOTING.
    - LAND SURVEYOR SHALL THEN PIN THE FOOTING TO PRECISELY SET THE BUILDING CORNERS.
    - CONTRACTOR SHALL SET FORMS AND POUR WALLS.
    - LAND SURVEYOR SHALL LOCATE FOUNDATION AND PROVIDE "AS-BUILT" DRAWING TO THE TOWN, TO ACQUIRE THE NEXT PART OF THE BUILDING PERMIT.
    - AFTER APPROVAL OF "AS-BUILT" DRAWING BY THE TOWN AND PROJECT ENGINEER, CONTRACTOR MAY CONTINUE WITH CONSTRUCTION OF THE BUILDING.
    - LAND SURVEYOR SHALL STAKE SANITARY SYSTEM AND STORMWATER MANAGEMENT SYSTEM.
    - CONTRACTOR SHALL CONTACT PROJECT ENGINEER AND SANITARIAN, THEN INSTALL SANITARY SYSTEM TO THE LINES AND GRADES SHOWN ON THE PLANS IN ACCORDANCE WITH THE DETAILS AND MANUFACTURES SPECIFICATIONS
    - INSTALL STORMWATER MANAGEMENT SYSTEM TO THE LINES AND GRADES SHOWN ON THE PLANS, DETAILS AND IN ACCORDANCE WITH THE MANUFACTURES SPECIFICATIONS.
    - PLACE GRAVEL FOR DRIVES AND PARKING AREAS.
    - PAVE DRIVE AND PARKING AREAS
    - REPLACE TOPSOIL. SEED AND MULCH ALL DISTURBED AREAS AS DESCRIBED IN THIS NARRATIVE AND IN "2002 CONNECTICUT GUIDELINES FOR SOIL EROSION AND SEDIMENT CONTROL".
    - MAINTAIN SILT FENCE AND/OR HAY BALE EROSION CONTROL UNTIL ALL DISTURBED AREAS ARE STABILIZED.
    - LAND SURVEYOR TO COMPLETE AS-BUILT DRAWING OF STORMWATER MANAGEMENT SYSTEM. PROJECT ENGINEER WILL THEN CONFIRM STORMWATER MANAGEMENT SYSTEM IS CONSISTENT WITH THE DESIGNED INTENT AND WILL ATTENUATE THE INCREASE IN SURFACE RUNOFF.
- III. SEEDING DATES:**
- TO ESTABLISH PERMANENT VEGETATION, SEEDING SHOULD BE PERFORMED BETWEEN APRIL 1 THROUGH JUNE 15 AND AUG 15 THROUGH OCTOBER 15. SHOULD GRADING BE COMPLETE DURING ANOTHER PERIOD, TEMPORARY SEEDING SHALL BE PERFORMED IN ACCORDANCE WITH ITEM V THIS SHEET
  - TEMPORARY OR PERMANENT SEEDING SHOULD BE PERFORMED WITHIN 7 DAYS AFTER ESTABLISHING FINAL GRADES.
  - WHEN GRADING WORK WITHIN A DISTURBED AREA IS TO BE SUSPENDED FOR A PERIOD OF MORE THAN 1 YEAR, PERMANENT SEEDING SHALL BE PROVIDED IN ACCORDANCE WITH SECTION IV THIS SHEET AND "2002 CONNECTICUT GUIDELINES FOR SOIL EROSION AND SEDIMENT CONTROL"
  - SHOULD WORK BE SUSPENDED ON A GRADING OPERATION AND SUCH SUSPENSION IS EXPECTED TO LAST FOR 1 TO 12 MONTHS, TEMPORARY SEEDING SHALL BE PROVIDED IN ACCORDANCE WITH ITEM V THIS SHEET AND "2002 CONNECTICUT GUIDELINES FOR SOIL EROSION AND SEDIMENT CONTROL"
- IV. PERMANENT SEEDING:**
- PERMANENT SEEDING SHALL BE PERFORMED IN ACCORDANCE WITH CHAPTER 5-3-5 OF THE "2002 CONNECTICUT GUIDELINES FOR SOIL EROSION AND SEDIMENT CONTROL".
  - SITE PREPARATION:
    - GRADE IN ACCORDANCE WITH LAND GRADING MEASURES AS SET FORTH IN CHAPTER 5-2-5 OF THE "2002 CONNECTICUT GUIDELINES FOR SOIL EROSION AND SEDIMENT CONTROL".
    - FOR AREAS TO BE MOWED REMOVE ALL SURFACE STONES 2 INCHES OR LARGER.
    - ON AREAS WHERE WOOD CHIPS OR BARK MULCH WAS PREVIOUSLY APPLIED, EITHER REMOVE THE MULCH OR INCORPORATE IT INTO THE SOIL WITH A NITROGEN FERTILIZER ADDED. (12 LBS NITROGEN PER TON OF WOOD CHIPS OR BARK MULCH)
- C. SEEDBED PREPARATION:**
- APPLY TOPSOIL, IF NECESSARY, IN ACCORDANCE WITH CHAPTER 5-2-2 OF THE "2002 CONNECTICUT GUIDELINES FOR SOIL EROSION AND SEDIMENT CONTROL".
  - APPLY FERTILIZER AND GROUND LIMESTONE ACCORDING TO SOIL TESTS CONDUCTED BY THE UNIVERSITY OF CONNECTICUT SOIL TESTING LABORATORY OR OTHER RELIABLE SOURCES.
  - WHERE SOIL TESTING IS NOT FEASIBLE, APPLY FERTILIZER AT THE RATE OF 300 POUNDS PER ACRE OR 7.5 POUNDS PER 1,000 SQUARE FEET USING 10-10-10 (NITROGEN - PHOSPHORIC ACID - POTASH) OR EQUIVALENT AND LIMESTONE A 4 TONES PER ACRE OR 200 POUNDS PER 1,000 SQUARE FEET.
  - APPLY LIME AT THE RATE OF 2 TONS PER ACRE.
  - APPLY SEED MIXTURE AS FOLLOWS:
    - 10 PERCENT PERENNIAL RYE GRASS
    - 45 PERCENT KENTUCKY BLUE GRASS
    - 45 PERCENT CREEPING RED FESCUE
- RATE OF APPLICATIONS: 5 POUNDS PER 1000 SF  
SEED TO A DEPTH OF FROM .25 TO .5 INCHES
- INSPECT SEEDED AREA AT LEAST ONCE A WEEK AND WITHIN 24 HOURS OF THE END OF A STORM WITH A RAINFALL AMOUNT FIRST GROWING SEASON.
  - MAINTAIN SEEDED AREA AS SET FORTH IN CHAPTER 5-2-5 AND IN ACCORDANCE WITH THE "2002 CONNECTICUT GUIDELINES FOR SOIL EROSION AND SEDIMENT CONTROL".
  - IF PERMANENT SEEDING AND STABILIZATION DOES NOT OCCUR PRIOR TO OCT 15, TEMPORARY VEGETATIVE COVER SHALL BE PROVIDED ON ALL DISTURBED AREAS IN ACCORDANCE WITH CHAPTER 5-3-2 OF THE "2002 CONNECTICUT GUIDELINES FOR SOIL EROSION AND SEDIMENT CONTROL" AND AS OUTLINED IN ITEM V.

- V. TEMPORARY VEGETATIVE COVER:**
- Temporary seeding shall be performed in accordance with Chapter 5-3-2 of the "2002 Connecticut Guidelines for Soil Erosion and Sediment Control".
  - Site Preparation:
    - Install necessary erosion control measures in accordance with approved plan.
    - Grade in accordance with Land Grading Measures as set forth in Chapter 5-2-5 of the "2002 Connecticut Guidelines for Soil Erosion and Sediment Control".
  - Seed Preparation:
    - Loosen the soil to a depth of 3-4 inches with a slightly roughened surface.
    - Apply fertilizer and ground limestone according to soil tests conducted by the University of Connecticut Soil Testing Laboratory or other reliable sources.
    - Where soil testing is not feasible, apply fertilizer at the rate of 300 pounds per acre or 7.5 pounds per 1,000 square feet using 10-10-10 (nitrogen - phosphoric acid - potash) or equivalent and limestone at 4 tones per acre or 200 pounds per 1,000 square feet.
    - Apply lime at the rate of 2 tons per acre.
    - Apply seed at a minimum rate for the selected seed identified in Figure below. Increase seeding rate by 10 percent when hydros seeding.

SPECIES (4)	SEEDING RATES (POUNDS)		DATE (1)	DEPTH (2)
	PER ACRE	PER 1,000 SF		
	OPTIMUM SEEDING			
Annual ryegrass	40	1.0	3/1 - 6/15 8/1 - 10/15	0.5
Perennial ryegrass	40	1.0	3/15 - 7/1 8/1 - 10/15	0.5
Winter rye	120	3.0	4/15 - 7/1 8/15 - 10/15	1.0
Oats	86	2.0	3/1 - 6/15 8/1 - 9/15	1.0
Winter wheat	120	3.0	4/15 - 7/1 8/1 - 10/15	1.0
Millet	20	0.5	5/15 - 7/15 5/15 - 8/1	1.0
Sudangrass	30	0.7	5/15 - 8/15	1.0
Buckwheat	15	0.4	4/1 - 9/15	1.0
Weeping lovegrass	5	0.2	6/1 - 7/1	0.25
DOT All Purpose Mix (3)	150	3.4	3/15 - 6/17 8/15 - 10/15	.5

- May be planted throughout summer if soil moisture is adequate or can be irrigated. Fall seeding may be extended 15 days in the coastal towns.
- Seed at twice the indicated depth for sandy soils.
- See Permanent Seeding Figure p5-3 of the "2002 Connecticut Guidelines for Soil Erosion and Sediment Control".
- Listed species may be used in combination to obtain a broader time spectrum. If used in combinations, reduce each species planting rate by 20 percent of that listed.
- Temporary seedings made during optimum seeding dates shall be mulched according to the "Mulch for Seed" measures as set forth in Chapter 5-4-5 of the "2002 Connecticut Guidelines for Soil Erosion and Sediment Control".
  - Hay, Straw, Cellulose Fiber, Tackifiers and Nettings are all acceptable types of mulches.
- Inspect seeded area at least once a week and within 24 hours of the end of a storm with a rainfall amount of .5 inches or greater for seed and mulch movement and rill erosion.
- Continue inspections until the grasses are firmly established.

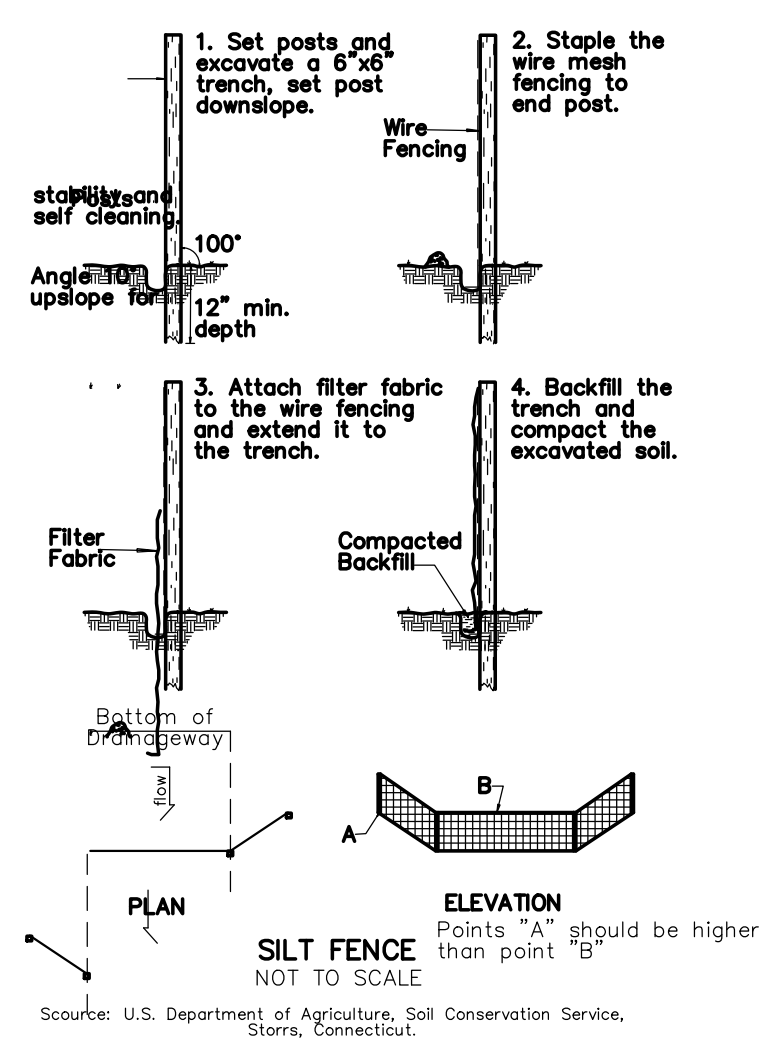

SILT FENCE  
NOT TO SCALE  
Source: U.S. Department of Agriculture, Soil Conservation Service, Storrs, Connecticut

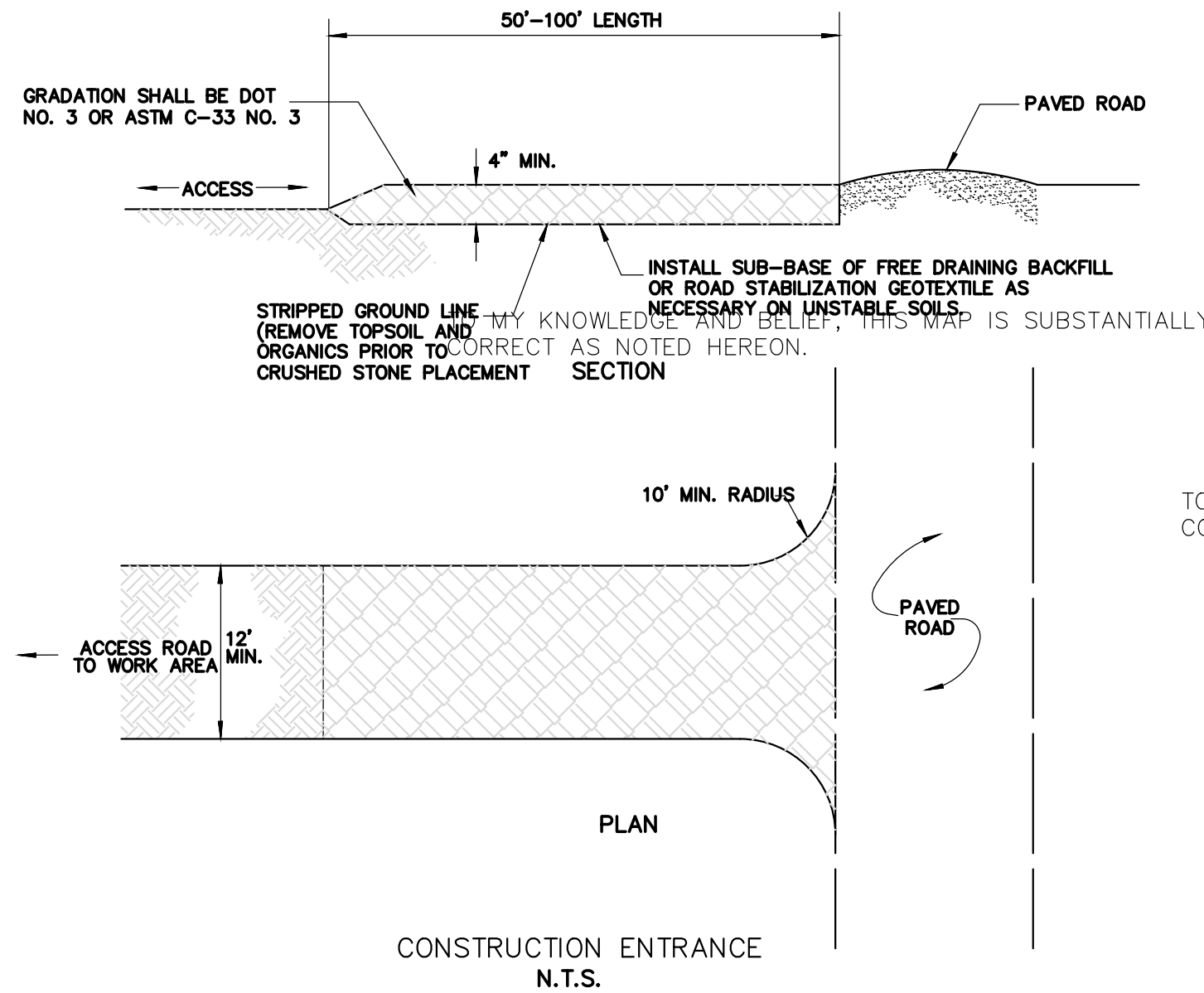

CONSTRUCTION ENTRANCE  
N.T.S.

TO MY KNOWLEDGE AND BELIEF, THIS MAP IS SUBSTANTIALLY CORRECT AS NOTED HEREON.

ROBERT L. DOANE, JR.  
CONN. P.E. & L.S. LIC. NO. 11463

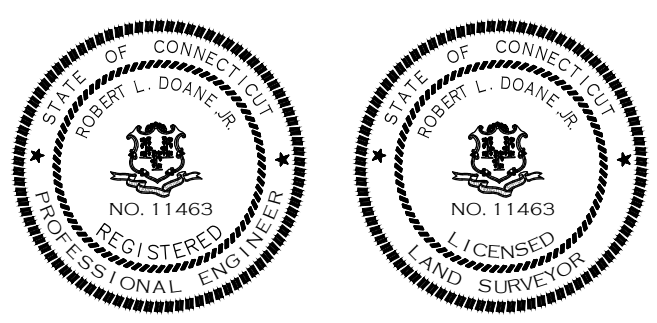

"SITE DETAILS"  
MAP #45 LOT #27-3

**DOANE ENGINEERING**  
CIVIL ENGINEERING AND LAND SURVEYING  
P.O. BOX 113 CENTERBROOK, CONNECTICUT 06409  
TEL: (860)767-0138, FAX: (860)767-9104

SITE PLAN  
PREPARED FOR  
PIAGE MANAGEMENT CORP  
#49 PLAINS ROAD, ESSEX, CONNECTICUT

SCALE: NOT TO SCALE	DATE: 11/03/22	SHEET NO.: 5 OF 7	IDENT. NO.:
------------------------	-------------------	----------------------	-------------

DATE	REVISION	CK.
12/12/22	TOWN COMMENTS	
01/06/23	TOWN COMMENTS	
01/10/23	REVISIONS	
02/06/23	TOWN COMMENTS	
02/10/23	BASIN PLANTING/BUILDING HEIGHT	

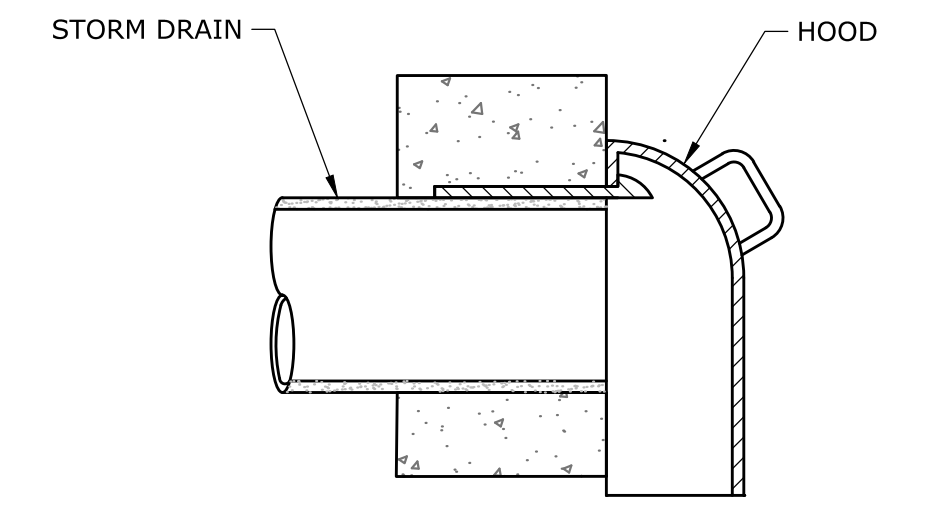
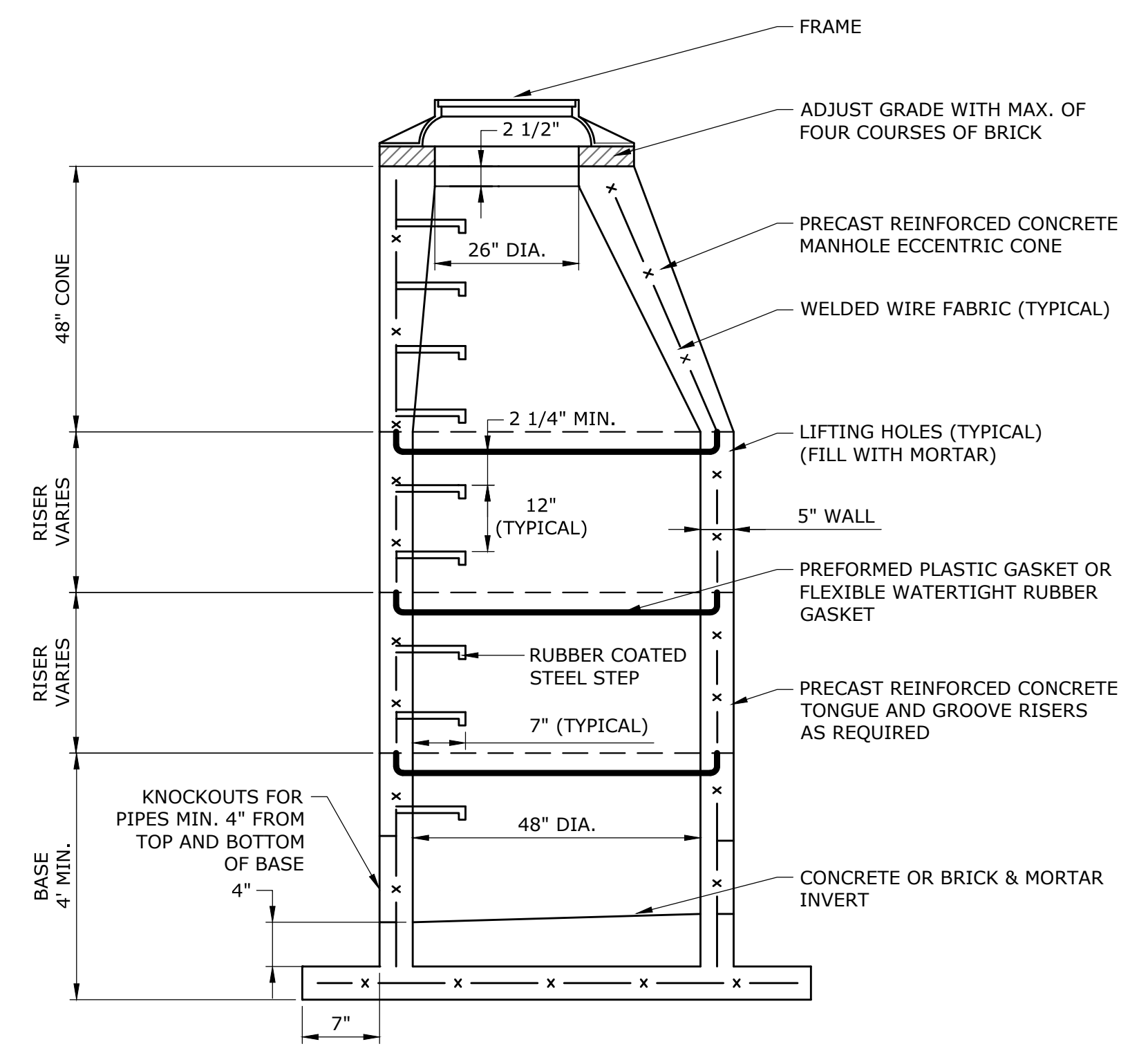

**NOTES:**  
1. HOODED OUTLET TO BE INSTALLED IN ALL CATCH BASINS

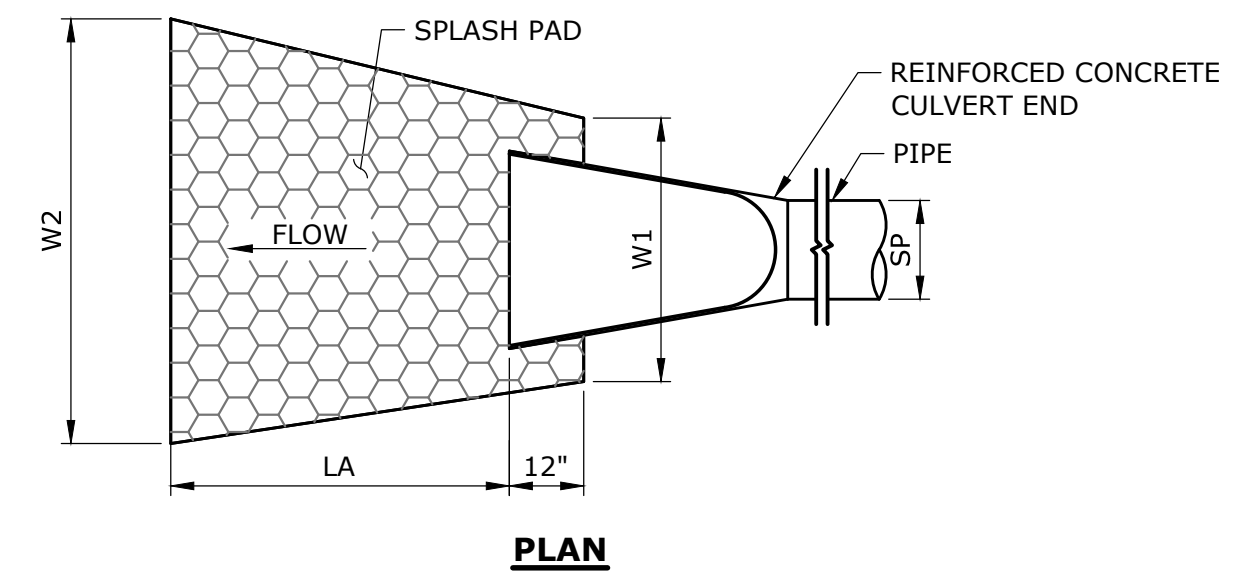

OUTLET PROTECTION ID	TYPE	SP (FT)	RP (FT)	LA (FT)	W1 (FT)	W2 (FT)	D (IN)
FES 1 FES 20	MODIFIED TYPE B	1.25	1.25	10.0	4.0	8.0	15
FES 8 FES 14	MODIFIED TYPE B	1.00	1.00	10.0	3.0	7.0	12

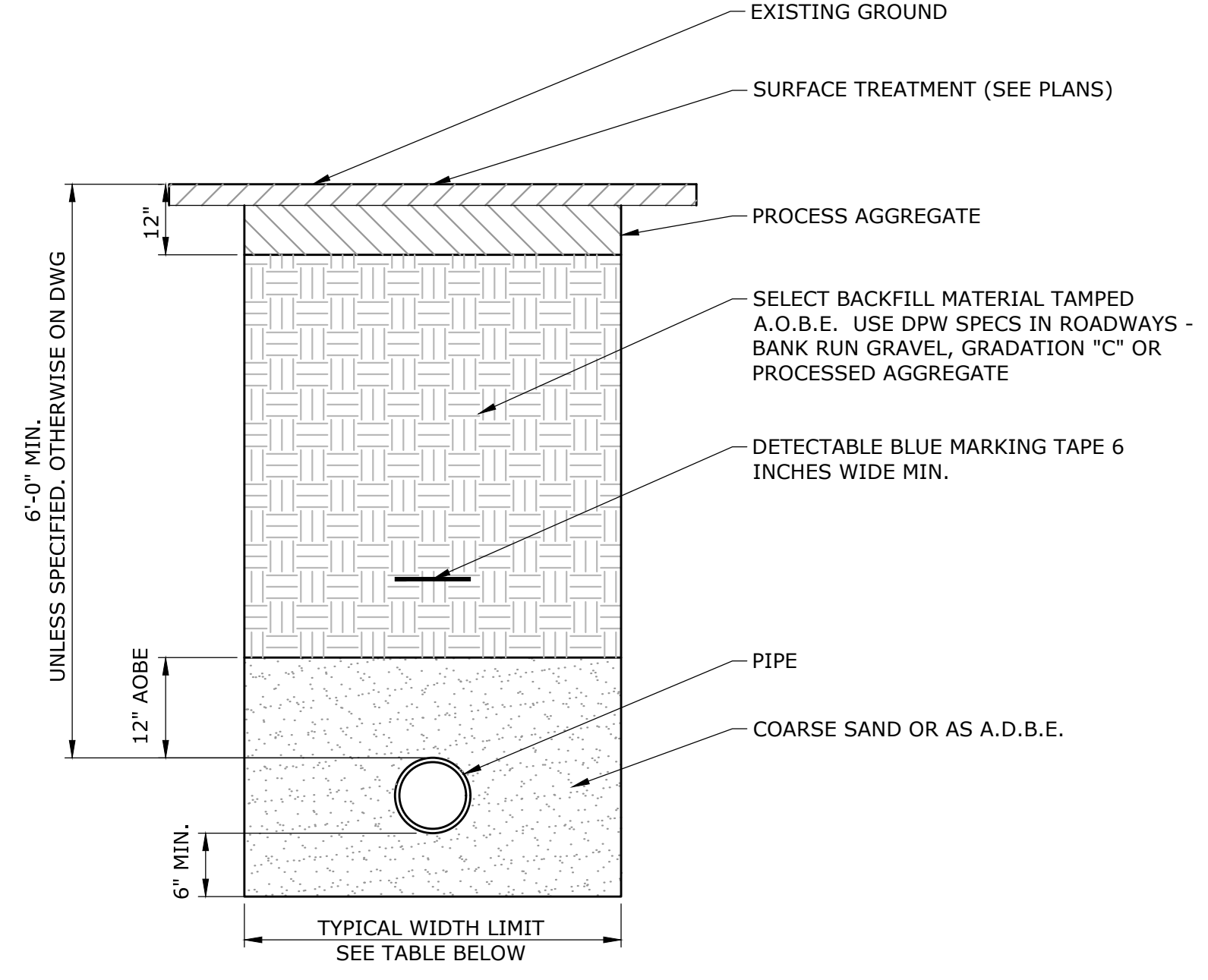
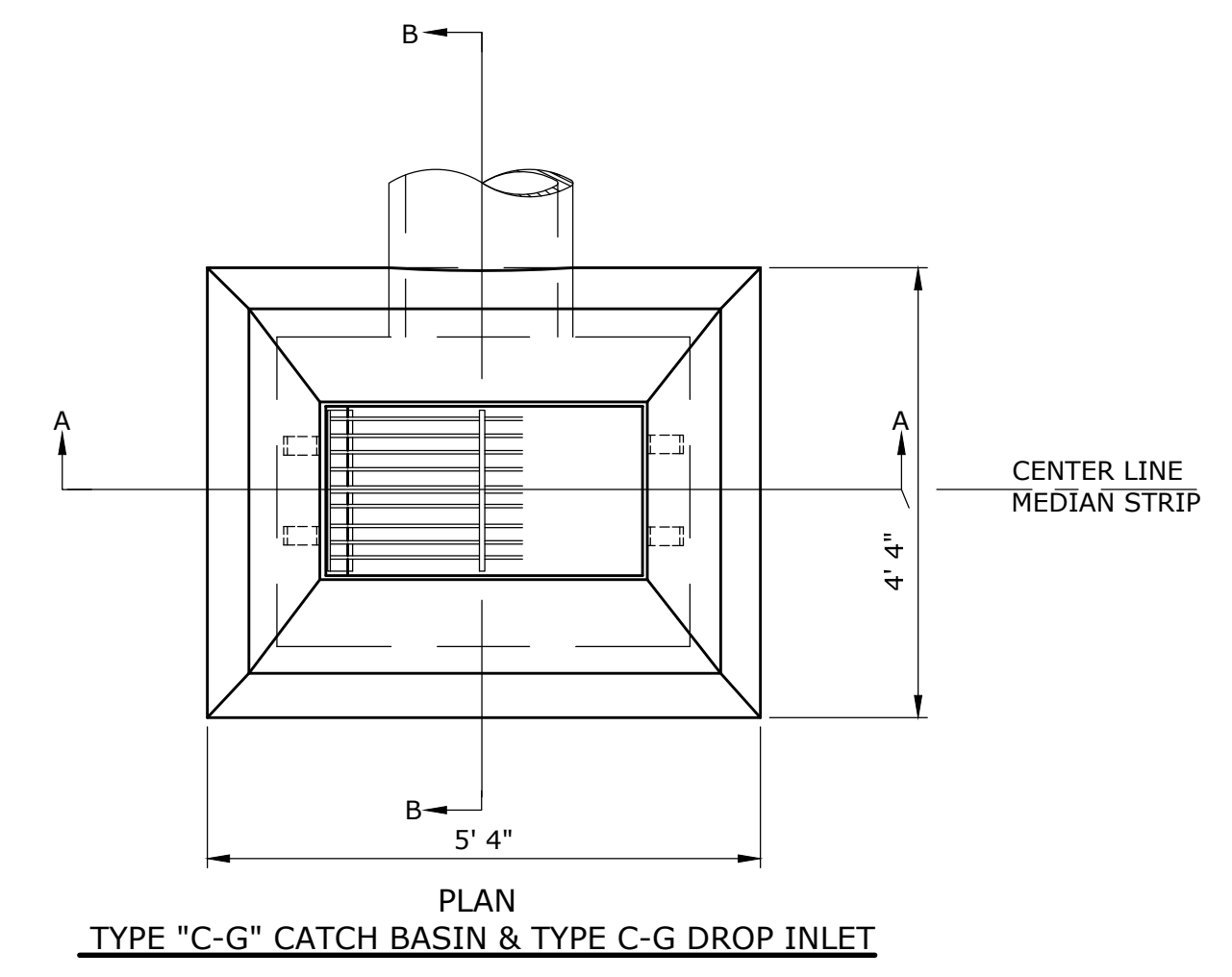

**STANDARD LIMITS**

PIPE SIZE	WIDTH	DEPTH
6"	3.0'	7"
8"	3.0'	7.5"
12"	3.0'	7.5"
16"	3.4'	8"
20"	3.9'	8"
24"	4.3'	8.5"
30"	4.5'	9"

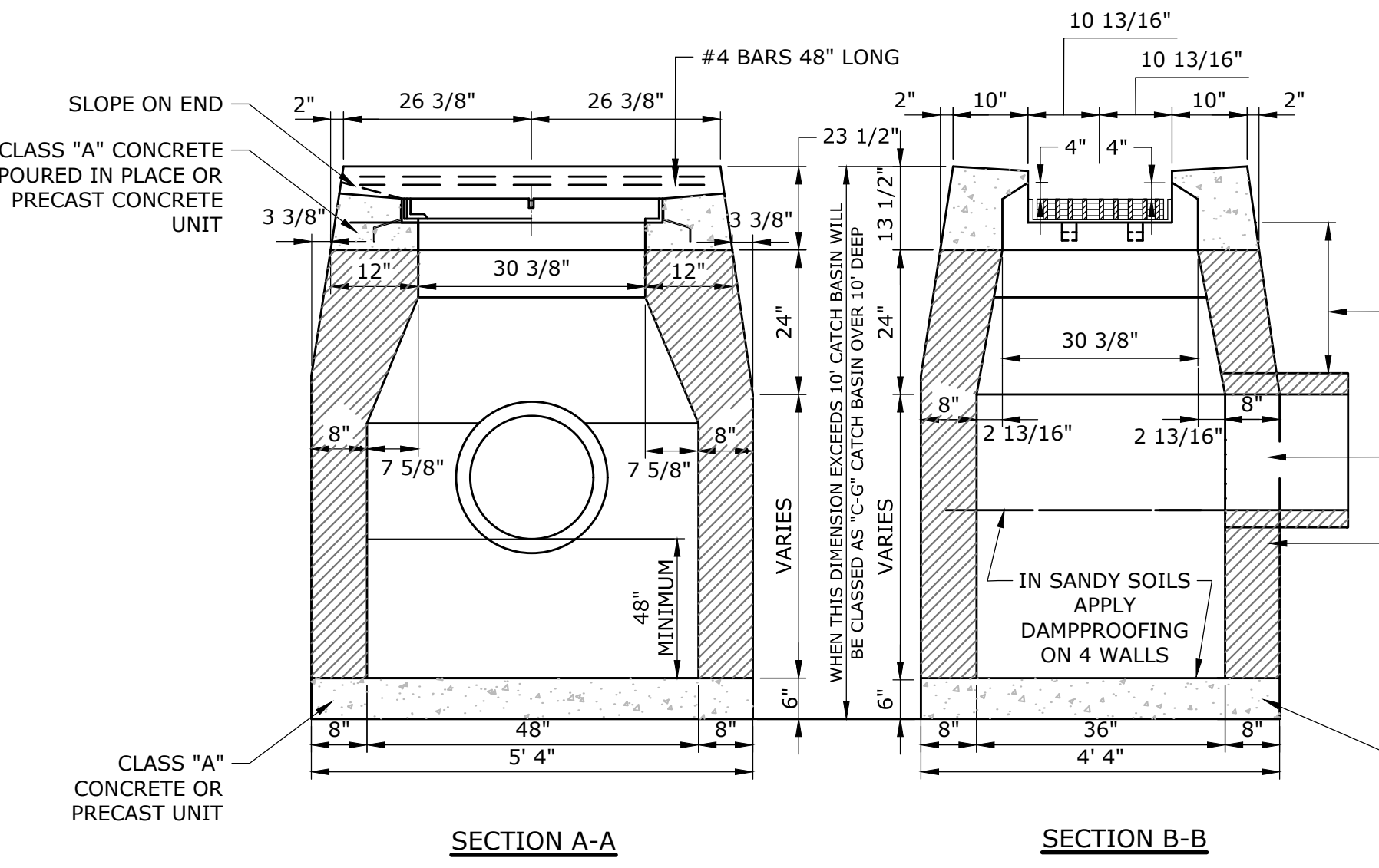

**NOTES:**  
1. MINIMUM DEPTH UNLESS SPECIFICALLY ORDERED OTHERWISE UNDER TRAVELWAY 19 1/2" UNDER UNTRAVELED AREAS 3"  
2. DRAINAGE OPENINGS IN 4 WALLS AT OR IMMEDIATELY ABOVE THIS ELEVATION  
3. PRECAST CONCRETE UNITS, BRICK CLASS "A" CONCRETE, MASONRY CONCRETE UNITY. WHERE BRICK OR MASONRY CONCRETE UNITS ARE USED, CORBELLING WILL BE PERMITTED. MAXIMUM CORBELL TO BE 3" NO PROJECTION SHALL EXTEND INSIDE OF LIMITS  
4. CLASS "A" CONCRETE OR PRECAST UNIT

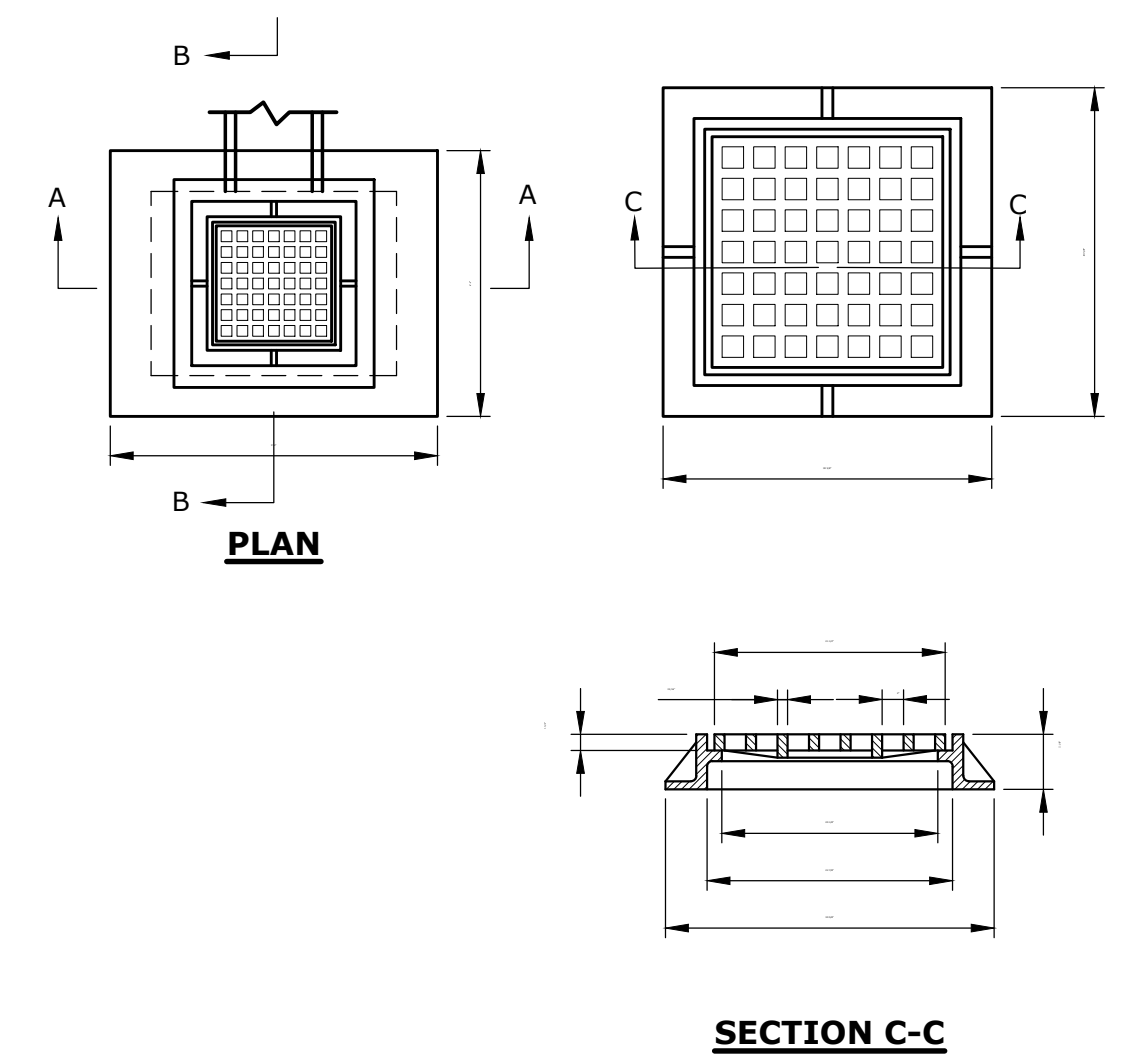
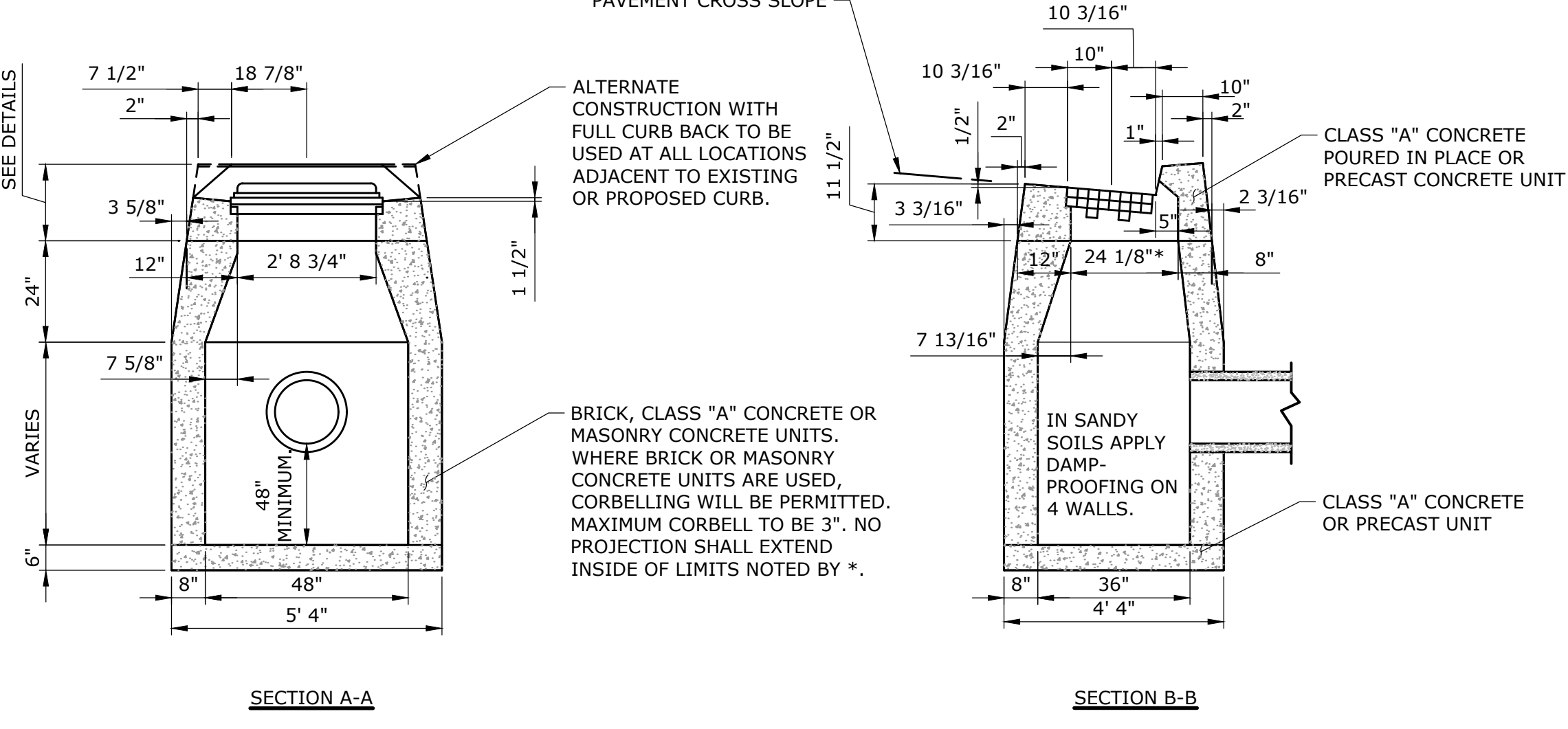
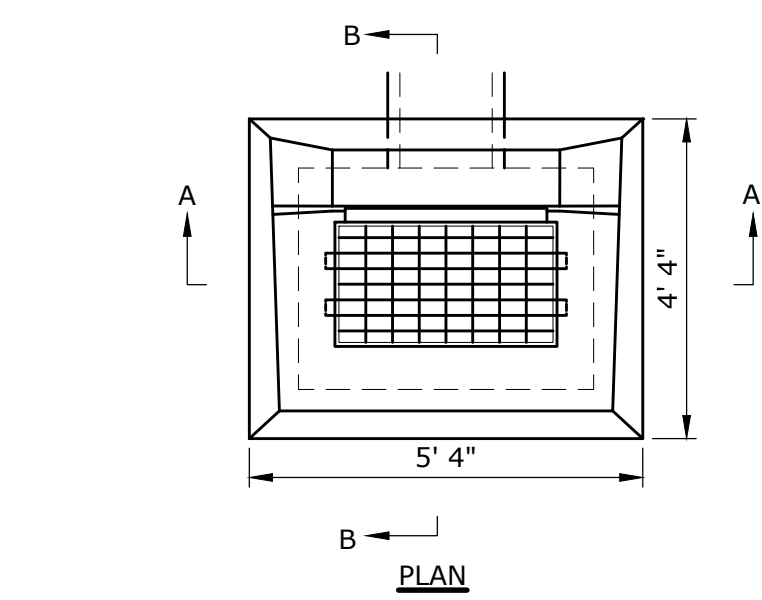

**NOTES:**  
1. YARD DRAIN FRAMES & GRATES SHALL BE PATTERN #R-3404 AS MANUFACTURED BY THE "NEENAH FOUNDRY COMPANY" OF NEENAH, WISCONSIN, OR APPROVED EQUAL.

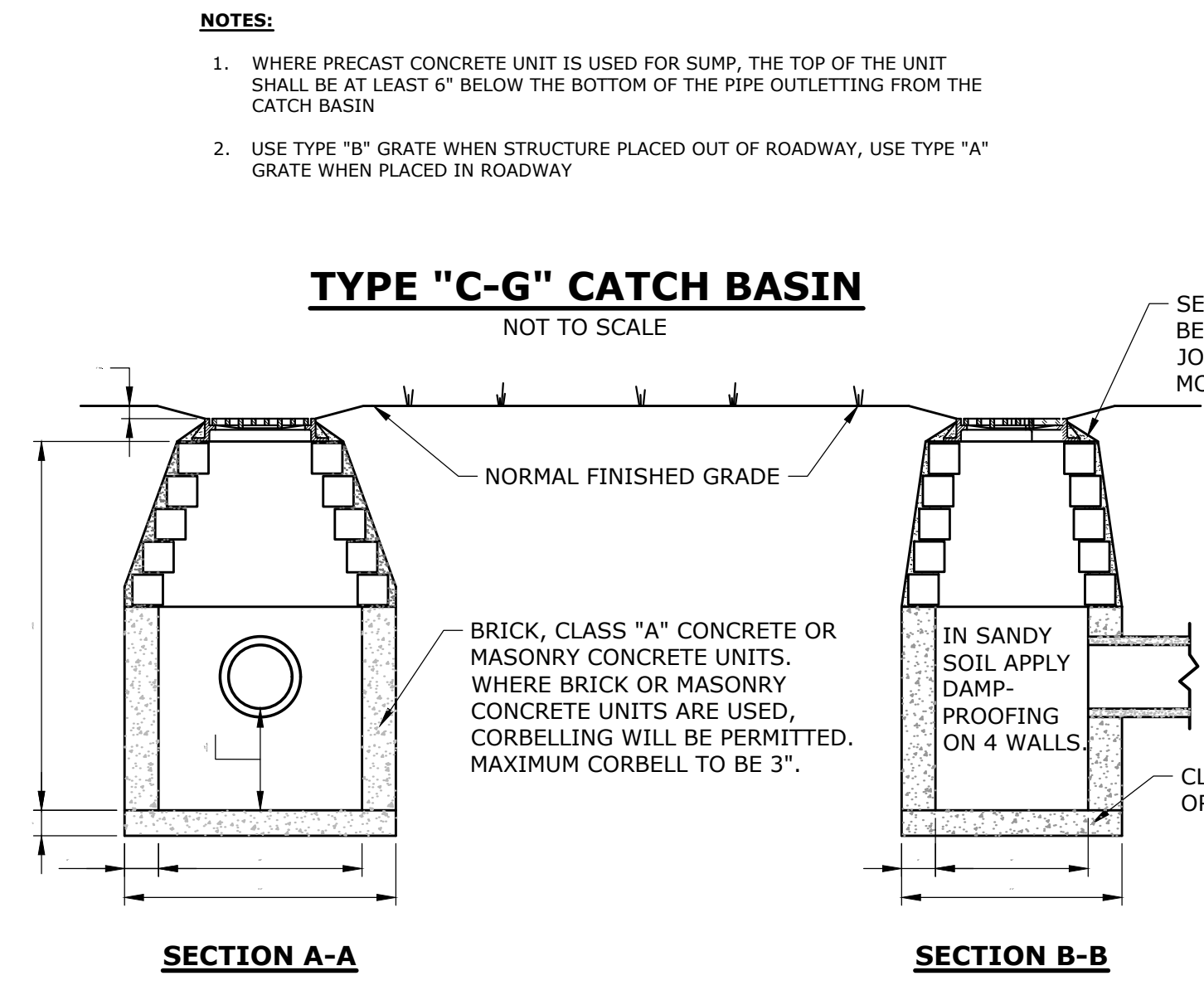

**NOTES:**  
1. WHERE PRECAST CONCRETE UNIT IS USED FOR SUMP, THE TOP OF THE UNIT SHALL BE AT LEAST 6" BELOW THE BOTTOM OF THE PIPE OUTLET FROM THE CATCH BASIN.

TO MY KNOWLEDGE AND BELIEF, THIS MAP IS SUBSTANTIALLY CORRECT AS NOTED HEREON.

*Robert L. Doane, Jr.*  
ROBERT L. DOANE, JR.  
CONN. P.E. & L.S. LIC. NO. 11463

"SITE DETAILS"  
MAP #45 LOT #27-3  
**DOANE ENGINEERING**  
CIVIL ENGINEERING AND LAND SURVEYING  
P.O. BOX 113 CENTERBROOK, CONNECTICUT 06409  
TEL: (860)767-0138, FAX: (860)767-9104

SITE PLAN  
PREPARED FOR  
PIAGE MANAGEMENT CORP  
#49 PLAINS ROAD, ESSEX, CONNECTICUT

SCALE: NOT TO SCALE	DATE: 11/03/22	SHEET NO.: 6 OF 7	IDENT. NO.:
------------------------	-------------------	----------------------	-------------

- CONSTRUCTION SEQUENCE (SANITARY SYSTEM)**
- NOTIFY TOWN HEALTH DEPARTMENT AND THE ENGINEER 48 HOURS PRIOR TO THE BEGINNING OF CONSTRUCTION. NO PORTION OF THE SYSTEM WILL BE COVERED WITHOUT INSPECTION AND APPROVAL BY THE ENGINEER OR THE SANITARIAN.
  - PLACE SILT FENCE AS SHOWN ON THE DRAWING AND IN THE DETAIL.
  - REMOVE ALL TREES, STUMPS AND DELETERIOUS MATERIAL FROM SYSTEM AREA.
  - STOCKPILE TOPSOIL FOR REUSE.
    - DO NOT STOCKPILE TOPSOIL IN SANITARY SYSTEM AREA.
    - DO NOT REMOVE SUBSOIL.
  - ENGINEER/LAND SURVEYOR SHALL FIELD STAKE THE PROPOSED SYSTEM PRIOR TO INSTALLATION.
  - INSTALL SEPTIC SYSTEM AS SHOWN.
    - SOIL CONDITIONS OTHER THAN THOSE SHOWN IN THE SOIL LOGS ARE ENCOUNTERED DURING THE INSTALLATION OF THE SANITARY SYSTEM, THE DESIGN ENGINEER OR THE SANITARIAN SHALL BE NOTIFIED AND THE WORK WILL BE HALTED PENDING REVIEW OF THOSE CONDITIONS. IF NECESSARY THE SANITARY SYSTEM SHALL BE REVISED.
    - A MINIMUM OF 4 FEET MUST BE MAINTAINED BETWEEN THE BOTTOM OF THE SYSTEM AND LEDGE. A MINIMUM OF 1.5 FEET MUST BE MAINTAINED BETWEEN THE BOTTOM OF THE SYSTEM AND SEASONAL HIGH GROUNDWATER.
  - DO NOT BACKFILL ANY PORTION OF THE SANITARY SYSTEM UNTIL INSPECTED BY THE SANITARIAN AND UNTIL A "RECORD" SURVEY HAS BEEN COMPLETED.
  - REPLACE TOPSOIL, GRADE, SEED AND MULCH ALL DISTURBED AREAS.
  - MAINTAIN SYNTHETIC FILTER BARRIER UNTIL ALL DISTURBED AREAS ARE STABILIZED.

- SANITARY SYSTEM NOTES:**
- NO LARGE CAPACITY TUBS (> 100 GALLON CAPACITY) ARE PLANNED AND WILL NOT BE PERMITTED IN THE PROPOSED RESIDENCE.
  - NO GARBAGE GRINDER INSTALLATION IS PLANNED FOR THE PROPOSED RESIDENCE. SHOULD A GARBAGE GRINDER BE INSTALLED THE PROPOSED SEPTIC TANK SHALL BE INCREASED TO 2,000 GALLON TANK.
  - WATER SUPPLY SHALL BE BY PUBLIC WATER.
  - ALL SOLID PIPING AFTER THE SEPTIC TANK TO BE 4" PVC ASTM D 3034, SDR 35.
  - FILTER FABRIC SHALL BE SELECTED FROM THE FOLLOWING TABLE:

**APPROVED FILTER FABRICS FOR COVERING STONE AGGREGATE**

MANUFACTURER	DESIGNATION NUMBER
AMERICAN ENGINEERING FABRICS	AEF-480
BRADLEY INDUSTRIAL TEXTILE	PHOENIX LIJOMA
CARTHAGE MILLS	M35
CULTEC	410
DUPONT	SF20
ENGINEERED SYNTHETIC PRODUCTS	TNS R020
GEO FABRICS	GF 150
L&M SUPPLY COMPANY	L&M 231
MIRAFI	65304 (4" WIDE), 65303 (3" WIDE)
SKAPS INDUSTRIES	SKAPS GT 120
SRW PRODUCTS	SRW PRODUCTS DF1
TERRA TEX	S01.5, P01.5
TYFAR	3151, 3201
US FABRIC INC.	US 1.5 CT

- NO DEVIATION FROM THIS PLAN WILL BE ALLOWED WITHOUT THE APPROVAL OF THE ENGINEER AND SANITARIAN.
- SEPTIC TANK CONSTRUCTION JOINTS SHALL BE SEALED WITH ASPHALT CEMENT. ALL PIPE CONNECTIONS TO THE SEPTIC TANK AND DISTRIBUTION BOXES SHALL BE SEALED WITH A POLYETHYLENE GASKET ("POLY-LOK" OR APPROVED EQUAL).
- SEPTIC TANK AND BAFFLES SHALL CONFORM TO SECTION V.A.1 TECHNICAL STANDARDS OF THE STATE HEALTH CODE.
- SEPTIC TANK SHALL BE TWO COMPARTMENT TANK WITH HEAVY DUTY STEEL HANDLES FOR MANHOLE ACCESS COVERS AND GAS BAFFLES INSTALLED ON OUTLET PIPING. SEPTIC TANK TO BE EQUIPPED WITH AN APPROVED NON-BY-PASS EFFLUENT FILTER AT THE OUTLET. SEE TABLE BELOW:

**APPROVED SEPTIC TANK EFFLUENT FILTERS**

MANUFACTURER	MODEL
BEAR ONSITE	ML2-416, ML2-920, ML3-910, ML3-916, ML3-925, ML3-932
BIO-MICROBICS	Sanitee Series, ST 416, ST 418, ST 818, ST 836, ST 1618, ST 1638
BOWCO INDUSTRIES	EF-235
GAG-SIMTECH	STF-110, STF-110-7R, STF-110-6W, STF-110-8B
NORWECO	BIO-KINETIC BK2000
ORENCO SYSTEMS	FT044-36, FT0854-36, FT1254-36, FT1554-36, FTJ0418
POLYLOK	PL-68, PL-122, PL-525, PL-625, GF 10-8, GF 10-16
PREMIER TECH	EFT-080
RISSEY PLASTICS	45 - CLIK N'STICK
TUF-TITE	EF-4, EF-6
ZABEL	A100, A300, A1800, A1801, A100-HIP, A300-HIP, A1800-HIP, A1801-HIP, A600-12, A600-8
ZOELLER/CLARUS	WW1 (170-0078), WW4 (5000-0007)

- STONE AGGREGATE MEANS BROKEN STONE, CRUSHED STONE, OR SCREENED GRAVEL MEETING DEPARTMENT OF TRANSPORTATION FORM #16 SPECIFICATION M.01.01 FOR NO. 4 OR NO. 6 STONE (AS SHOWN BELOW OR LATEST SPECIFICATION). STONE AGGREGATE SHALL BE FREE OF SILT, DIRT OR DEBRIS AND SHALL SHOW A LOSS OF ABRASION OF NOT MORE THAN 50 PERCENT USING AASHTO METHOD T-96.

SIEVE SIZE	PERCENT PASSING (by weight)	PERCENT PASSING (by weight)
2 - INCH	100	N/A
1.5 INCH	90-100	N/A
1 INCH	20-55	100
3/4 INCH	0-15	90-100
1/2 INCH	N/A	20-55
3/8 INCH	0-5	0-15
#4	N/A	0-5
#10	0-3	0-3
#200	0-15	0-15

**GST "62" LEACHING SYSTEM H-20**

Finished Grade shall be pitched to sheet flow stormwater away from

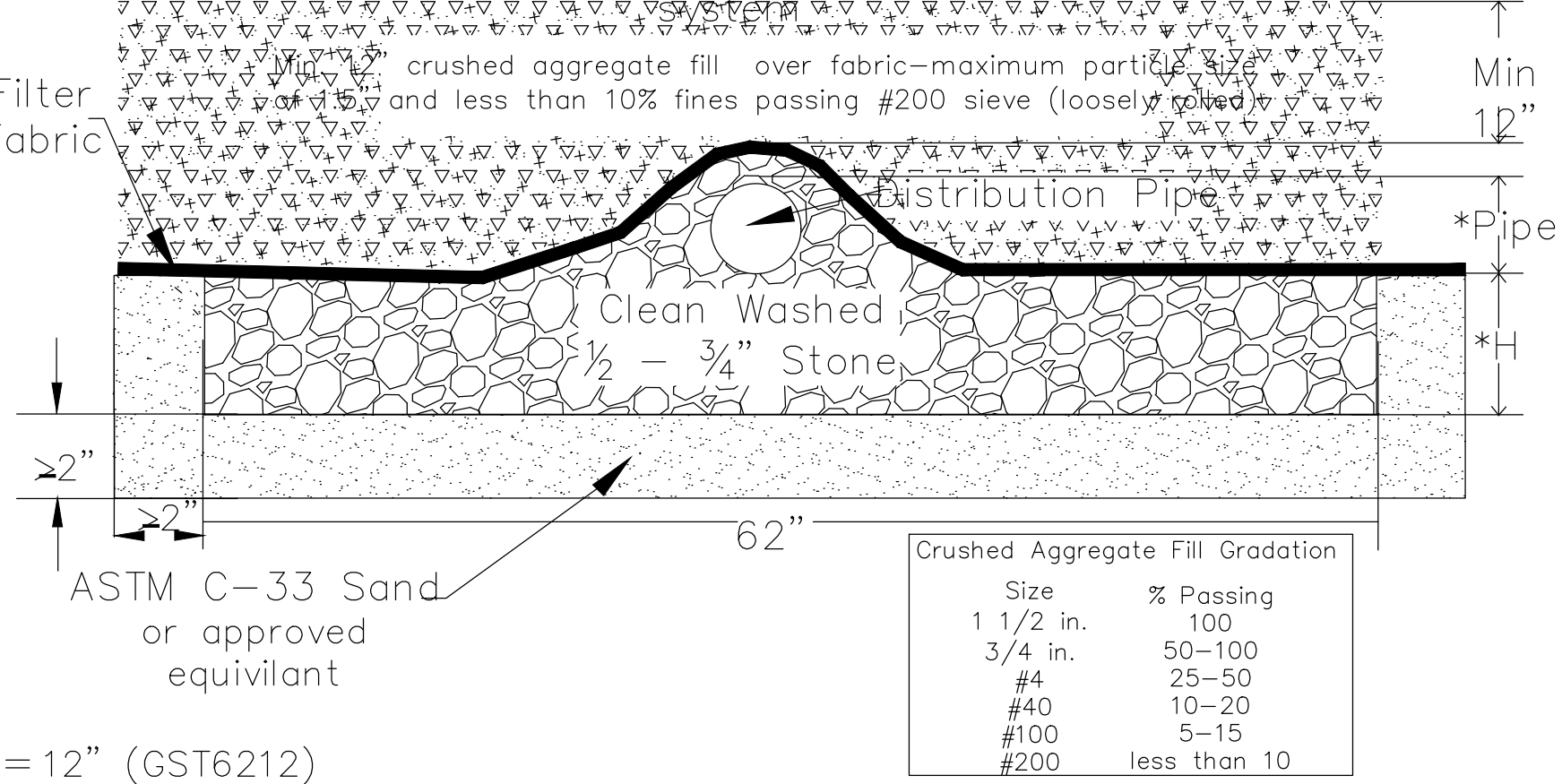

**Crushed Aggregate Fill Gradation**

Size	% Passing
1 1/2 in.	100
3/4 in.	50-100
#4	25-50
#10	10-20
#100	5-15
#200	less than 10

**Test Hole Data**  
Performed by Doane Engineering & Don Mitchell, R.S., Town of Essex 3/16/21

**TH 1**

0 - 10" Topsoil, leaf litter (organic)  
10 - 42" Yellow/brown very fine sand with silt  
42 - 84" Yellow/brown medium to coarse sand, trace silt and fine gravel

Roots observed to 50"  
No ledge observed  
Groundwater observed at 55"  
No mottling observed

**TH 2**

0 - 10" Topsoil, leaf litter (organic)  
10 - 30" Yellow/brown silt with very fine sand  
30 - 88" Yellowish red (grading to tan/brown) medium to coarse sand with little gravel

Roots observed to 38"  
No ledge observed  
Groundwater observed at 51"  
Mottling observed at 38"

**TH 3**

0 - 10" Topsoil, leaf litter (organic)  
10 - 40" Yellow/brown silt loam  
40 - 84" Tan medium to coarse sand with fine to medium gravel

Roots observed to 44"  
No ledge observed  
Groundwater observed at 46"  
No mottling observed

**TH 4**

0 - 6" Topsoil, leaf litter (organic)  
6 - 30" Yellow silty very fine sand  
30 - 84" Tan medium to coarse sand with trace fine gravel

Roots observed to 46"  
No ledge observed  
Groundwater observed 48" (seepage)  
Mottling observed at 36"

**TH 11**

0 - 6" Process stone  
6 - 24" Orange brown silty fine sandy loam (firm)  
24 - 37" Brown medium to coarse sand & gravel, some silt  
37 - 51" Reddish brown medium to coarse sand and gravel (loose)  
No ledge observed  
Groundwater (seepage observed at 58")

**TH 12**

0 - 48" Fill  
48 - 73" Topsoil  
No ledge observed  
Groundwater observed at 60"

**TH 13 (By Doane Engineering)**

0 - 8" Topsoil  
8 - 34" Yellow brown very fine sand and silt  
34 - 54" Yellow brown medium to coarse sand and gravel, trace silt  
Roots observed to 12"  
No ledge observed  
Groundwater observed to 37"  
Permeability Test A, B = 25"  
Permeability Test C, D = 38"

**TH 14 (By Doane Engineering)**

0 - 8" Topsoil  
8 - 47" Yellow brown very fine sand and silt  
Roots observed to 12"  
No ledge observed  
Groundwater observed at 39"  
Seepage observed at 34"  
Permeability Test E, F = 30"

**Test Hole Data**  
Performed by Doane Engineering & Don Mitchell, R.S., Town of Essex 01/18/22

**TH 5**

0 - 7" Topsoil and organic (fill)  
7 - 28" Greyish to olive brown fine sand (fill)  
28 - 37" Orange brown medium to coarse sand and gravel (fill)  
37 - 40" Orange brown silt loam (fill)  
40 - 43" Organic topsoil  
43 - 66" Tan silty loam  
66 - 87" Orange brown coarse sand and gravel  
No ledge observed  
No mottling observed  
Roots observed at 54"  
Groundwater observed at 83"

**TH 6**

0 - 4" Topsoil organics (fill)  
12 - 27" Brown fine-medium sand (fill)  
27 - 41" Tan fine sand, some gravel (fill)  
41 - 44" Organic topsoil  
44 - 62" Orange brown very fine sandy loam, Some silt  
62 - 83" Brown coarse sand and gravel  
No ledge observed  
Mottling observed at 58"  
Roots observed at 62"  
Groundwater observed at 76"

**TH 7 (NOT OBSERVED BY HEALTH DEPARTMENT)**

0 - 10" Topsoil  
10 - 60" Orange brown silty very fine sandy loam

No ledge observed  
Roots observed at 38"  
NO Mottling observed  
Groundwater observed at 60"

**TH 8 (NOT OBSERVED BY HEALTH DEPARTMENT)**

0 - 9" Topsoil  
9 - 50" Orange brown silty very fine sandy loam

No ledge observed  
Roots observed at 13"  
Mottling observed at 30"  
Groundwater observed at 50"

**TH 9**

0 - 11" Topsoil  
11 - 31" Orange brown silty very fine sandy loam and gravel  
31 - 51" Brown to red brown coarse sand and gravel  
51 - 86" Grey sand and gravel (wet)  
No ledge observed  
Roots observed at 51"  
Mottling observed at 60"  
Groundwater observed at 61" (seeps)

**TH 10**

0 - 10" Topsoil  
10 - 27" Orange brown silty very fine sandy loam  
27 - 88" Red to grey coarse sand and gravel  
No ledge observed  
Roots observed at 37"  
Mottling observed at 52"  
Groundwater observed at 61" (seeps)

**PERCOLATION TEST**  
PERFORMED BY DOANE ENGINEERING 1/19/22

**Perc 3 (Between TH9 and TH10)**  
Presoak Start: 1/18/22 4:00 (pm)  
Presoak Finish: 1/19/22 7:40 (am)  
Depth: 36" Fill: 36" Refill: 36"  
Ground Water at: 61" (TH9 and TH10)

Time	Depth
7:40	1 3/4"
7:50	3"
8:00	3 3/4"
8:10	4 1/2"
8:20	5 1/2"
8:30	6 1/2"
8:40	7 1/2"

Percolation Rate = 1 - 10.1 min./in.

**PERCOLATION TEST**  
PERFORMED BY DOANE ENGINEERING 4/14/21

**Perc 1 (TH4)**  
Presoak Start: 11:04 (am)  
Presoak Finish: 11:43 (am)  
Depth: 24" Fill: 12" Refill: 12"  
Ground Water at: 44" (TH4)

Time	Depth
11:57	11 1/2"
12:02	13 3/8"
12:07	14 5/8"
12:12	15 3/4"
12:17	17"
12:22	18 1/8"
12:27	18 3/4"
12:32	19 5/8"
12:37	20 1/4"
12:42	20 7/8"
12:47	21 5/8"
12:52	22 3/8"
12:57	Done

Percolation Rate = 1 - 10.1 min./in.

**Perc 2 (TH2)**  
Presoak Start: 11:14 (am)  
Presoak Finish: 11:55 (am)  
Depth: 24" Fill: 12" Refill: 11 1/2"  
Ground Water at: 44" (TH2)

Time	Depth
11:59	12"
12:04	14"
12:09	15 1/4"
12:14	16 3/8"
12:19	17 3/8"
12:24	18 3/8"
12:29	19 1/8"
12:34	19 7/8"
12:39	20 3/8"
12:44	21"
12:49	21 5/8"
12:54	22 3/8"
12:59	Done

Percolation Rate = 1 - 10.1 min./in.

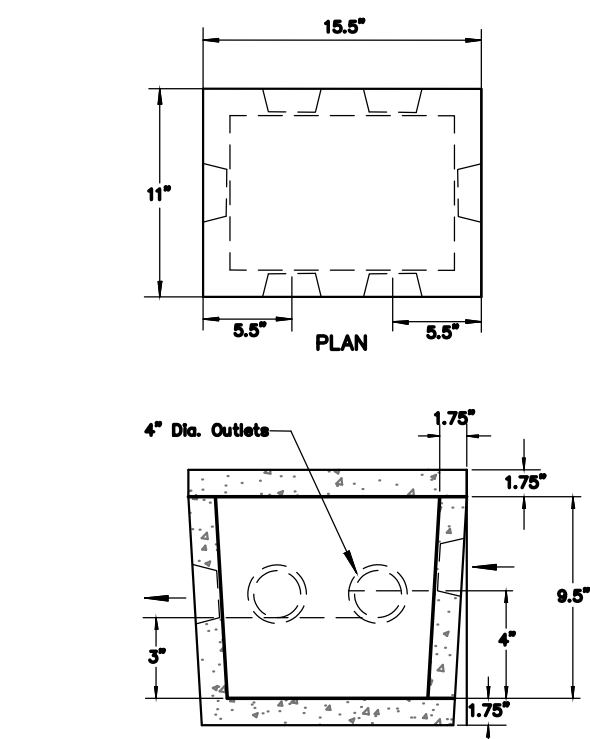

**SECTION DISTRIBUTION BOX (H-20 LOADING) N.T.S.**

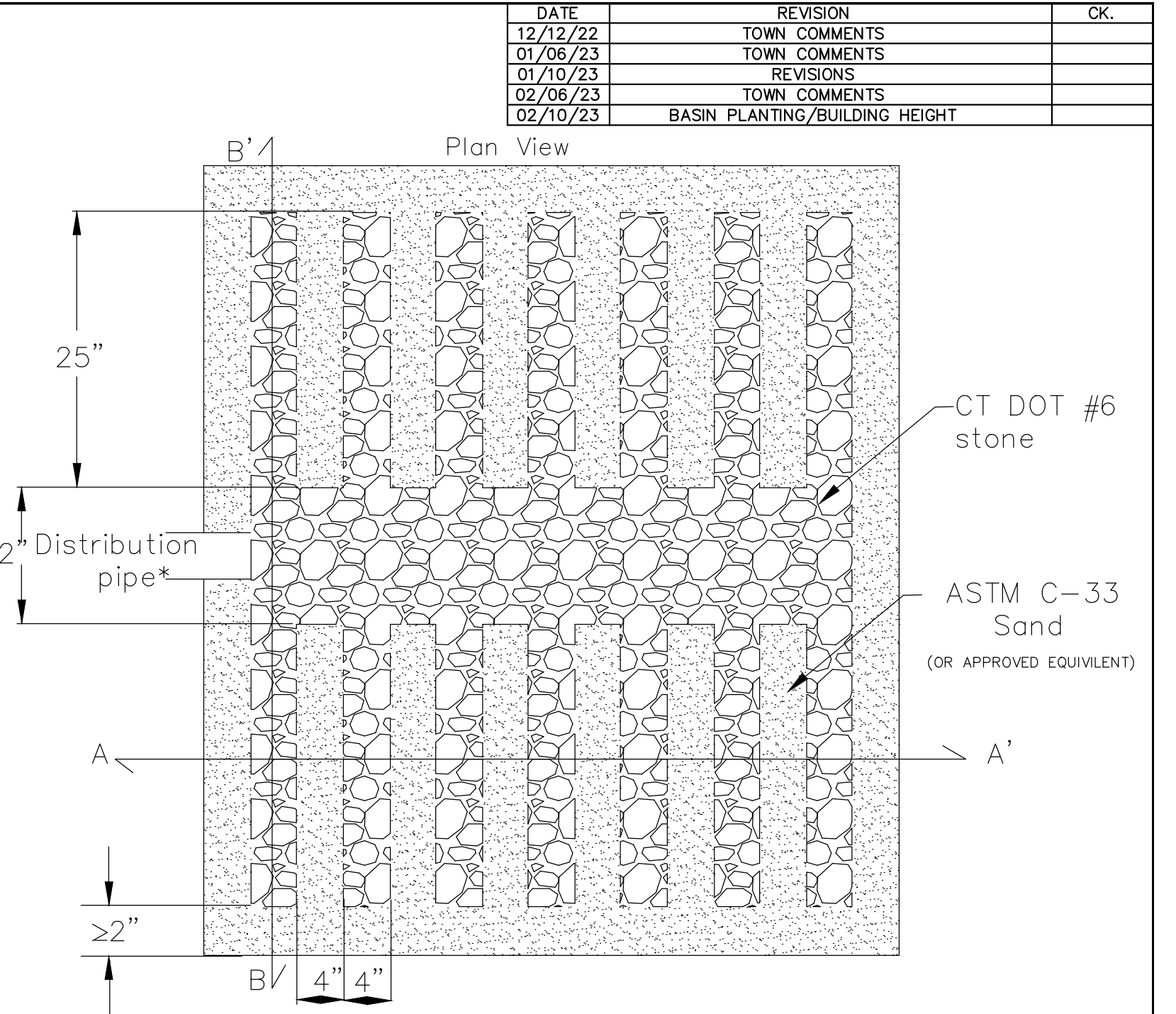

\*3" min. I.D., ASTM D-3034, SDR 35 pipe for gravity applications  
0.75" min. I.D., ASTM D-2665, SCH 40 PVC pipe for pressure applications

**GEOMATRIX GST™ LEACHING SYSTEM**  
SCALE: N.T.S.

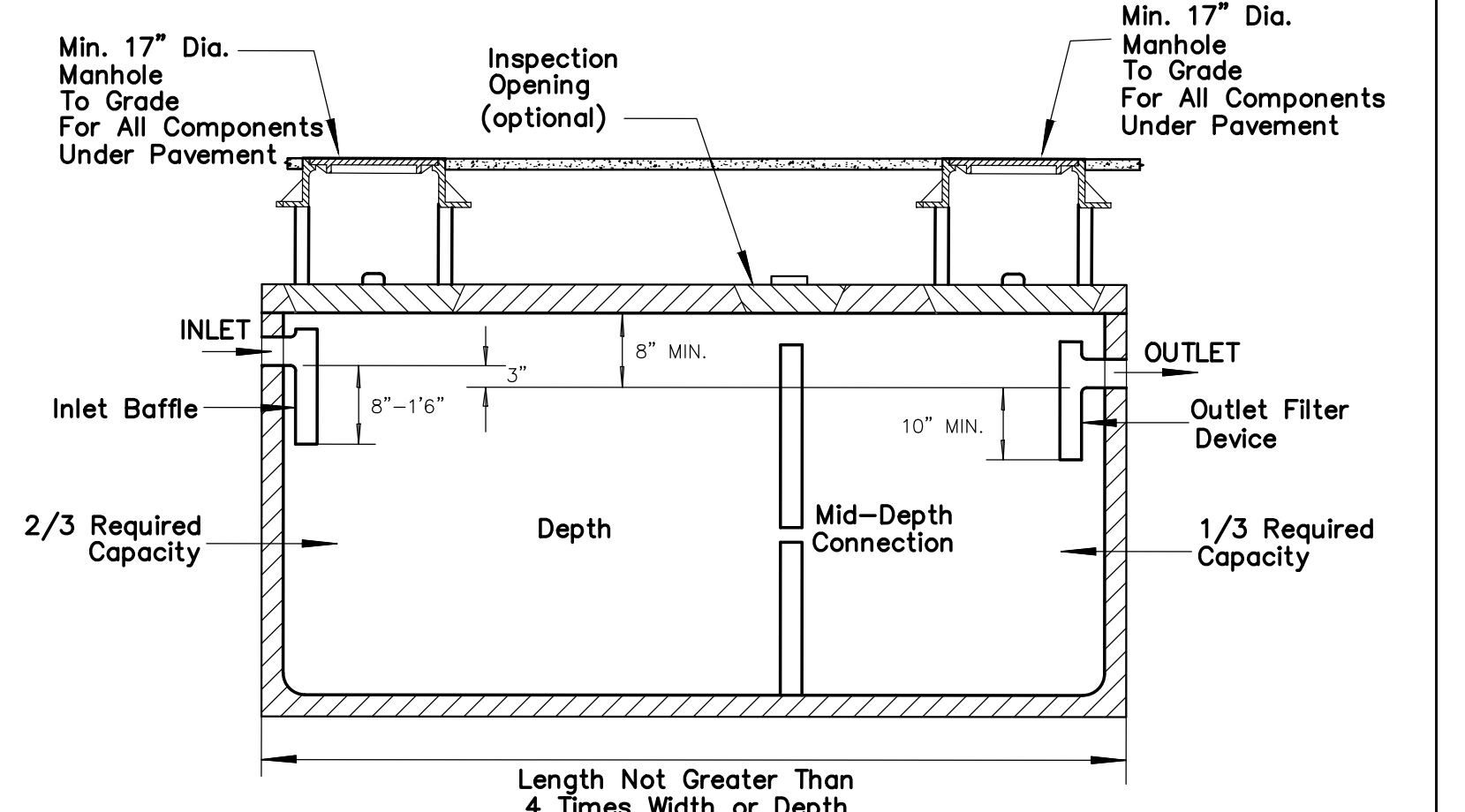

**TYPICAL SEPTIC TANK (H-20 LOADING)**

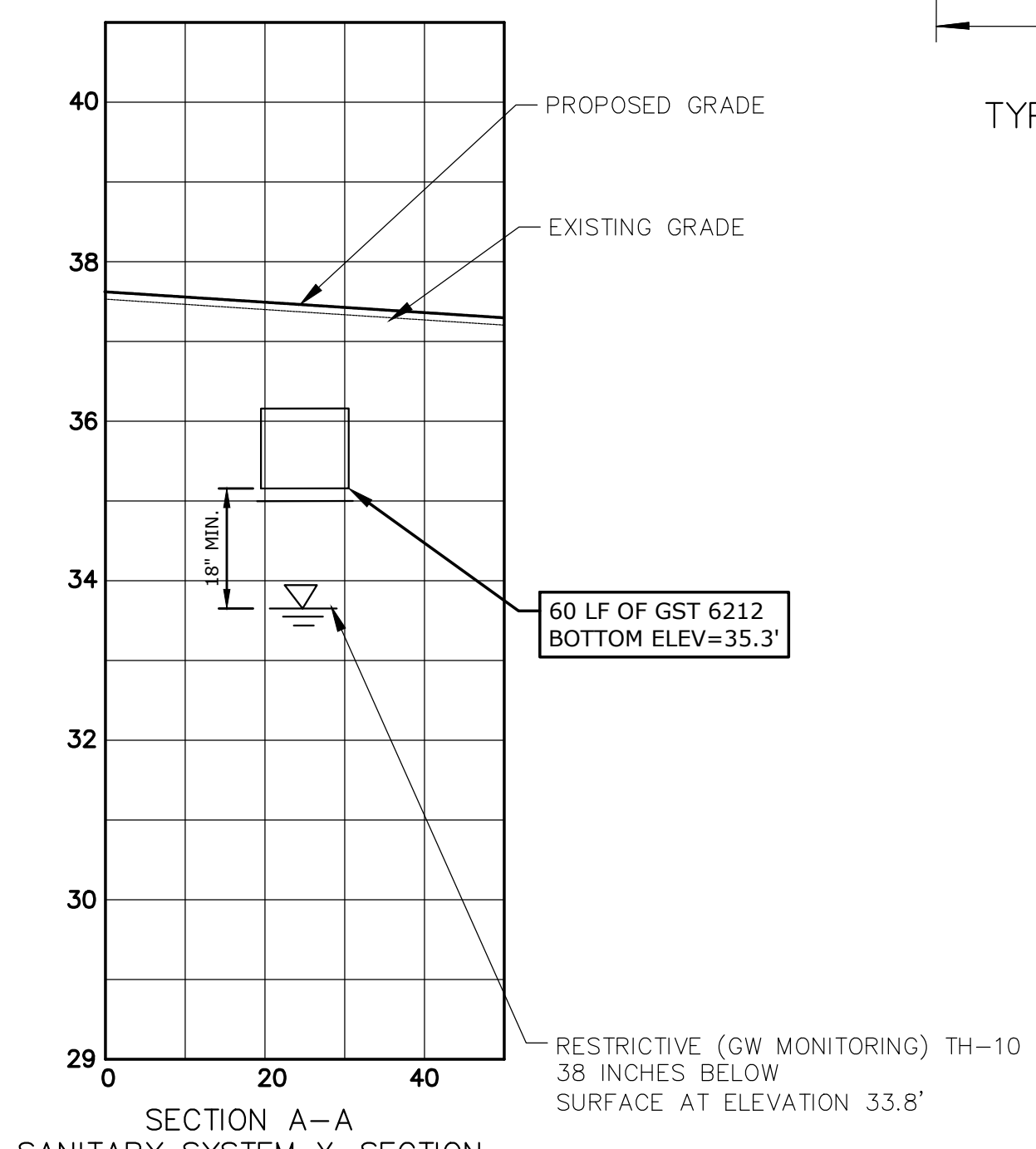

**SECTION A-A SANITARY SYSTEM X-SECTION**  
HORIZ. SCALE: 1" = 20'  
VERT. SCALE: 1" = 2'

TO MY KNOWLEDGE AND BELIEF, THIS MAP IS SUBSTANTIALLY CORRECT AS NOTED HEREON.

*Robert L. Doane, Jr.*  
ROBERT L. DOANE, JR.  
CONN. P.E. & L.S. LIC. NO. 11463

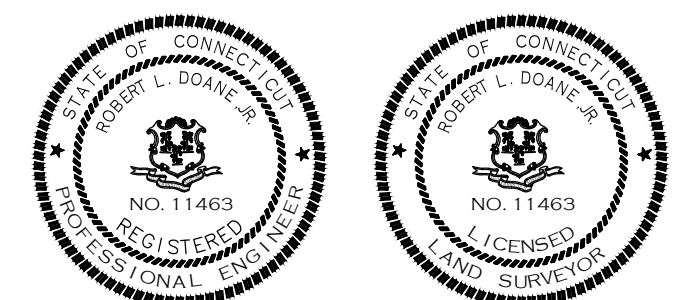

**"SITE DETAILS"**  
MAP #45 LOT #27-3

**DOANE ENGINEERING**  
CIVIL ENGINEERING AND LAND SURVEYING  
P.O. BOX 113 CENTERBROOK, CONNECTICUT 06409  
TEL: (860)767-0138, FAX: (860)767-9104

**SITE PLAN PREPARED FOR PIAGE MANAGEMENT CORP #49 PLAINS ROAD, ESSEX, CONNECTICUT**

SCALE:	DATE:	SHEET NO.:	IDENT. NO.:
NOT TO SCALE	11/03/22	7 OF 7	