

DATE	REVISION	CK.

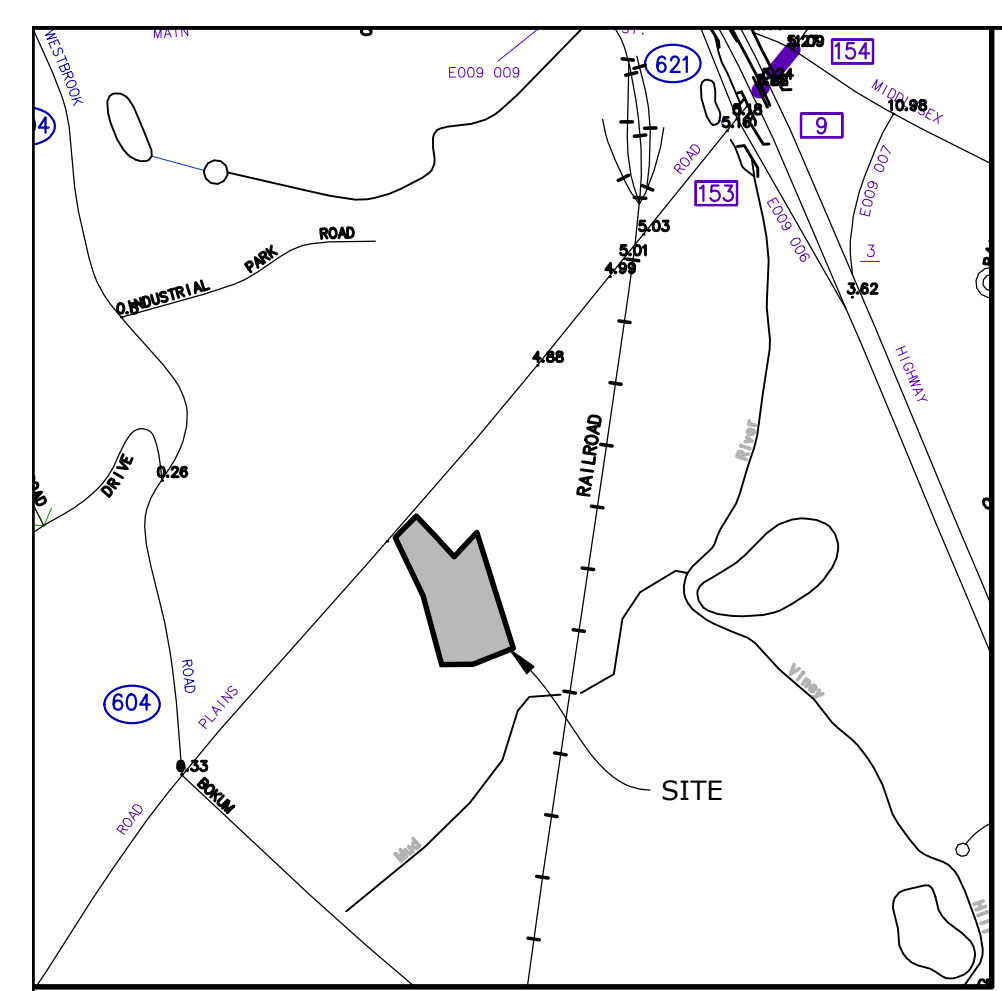

LOCATION MAP
SCALE: 1"=1000'±

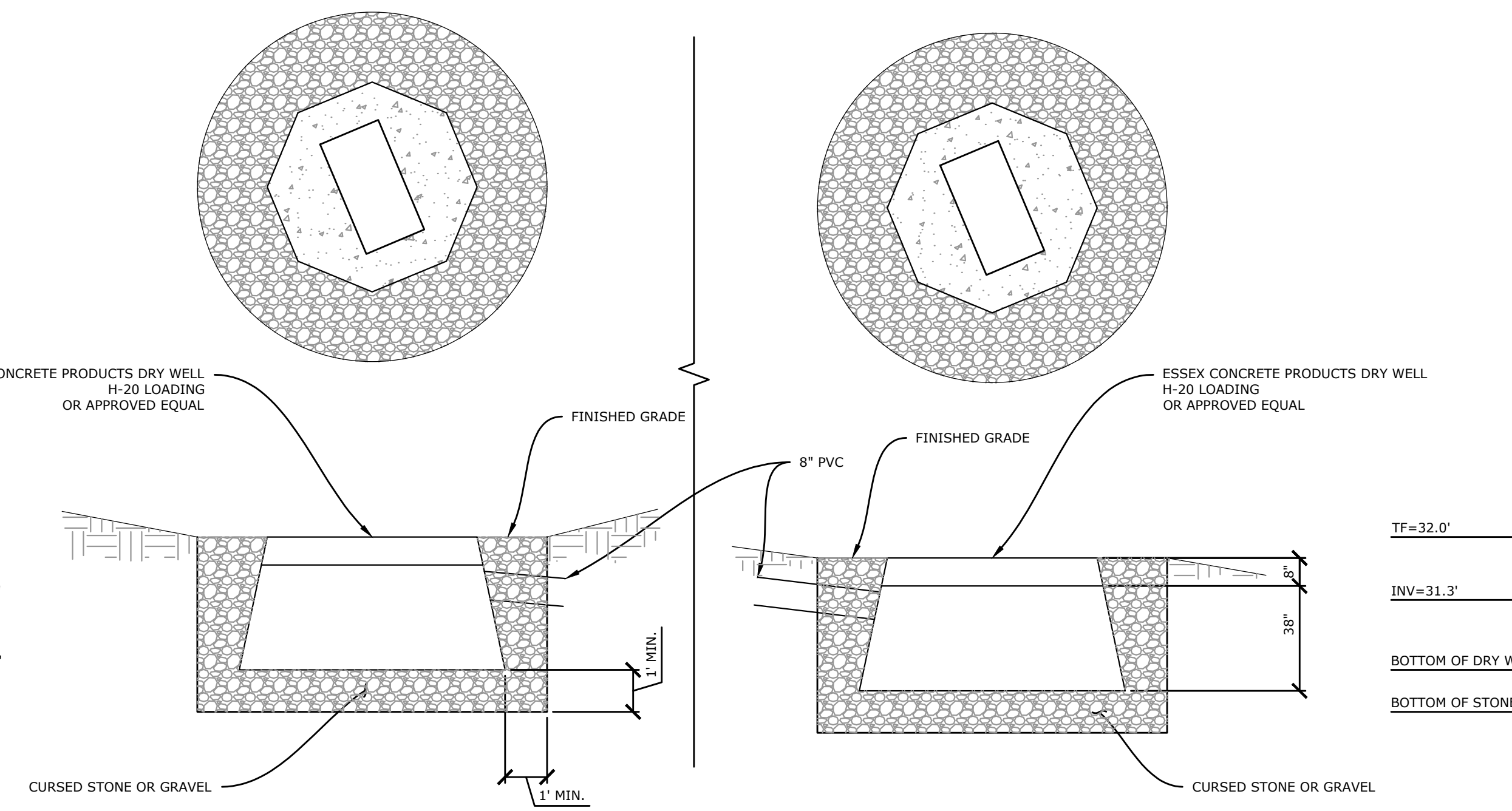
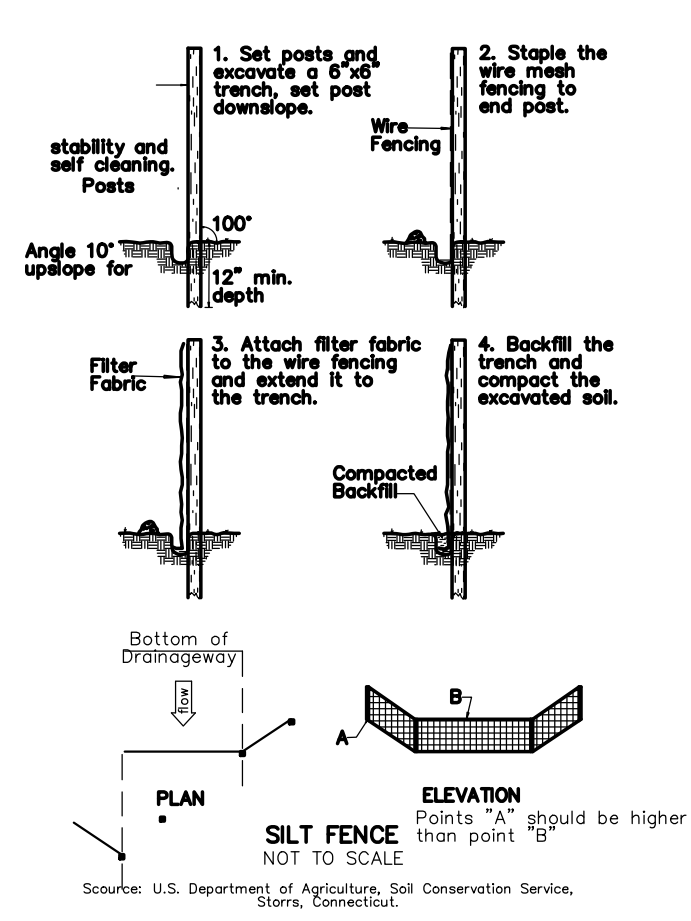
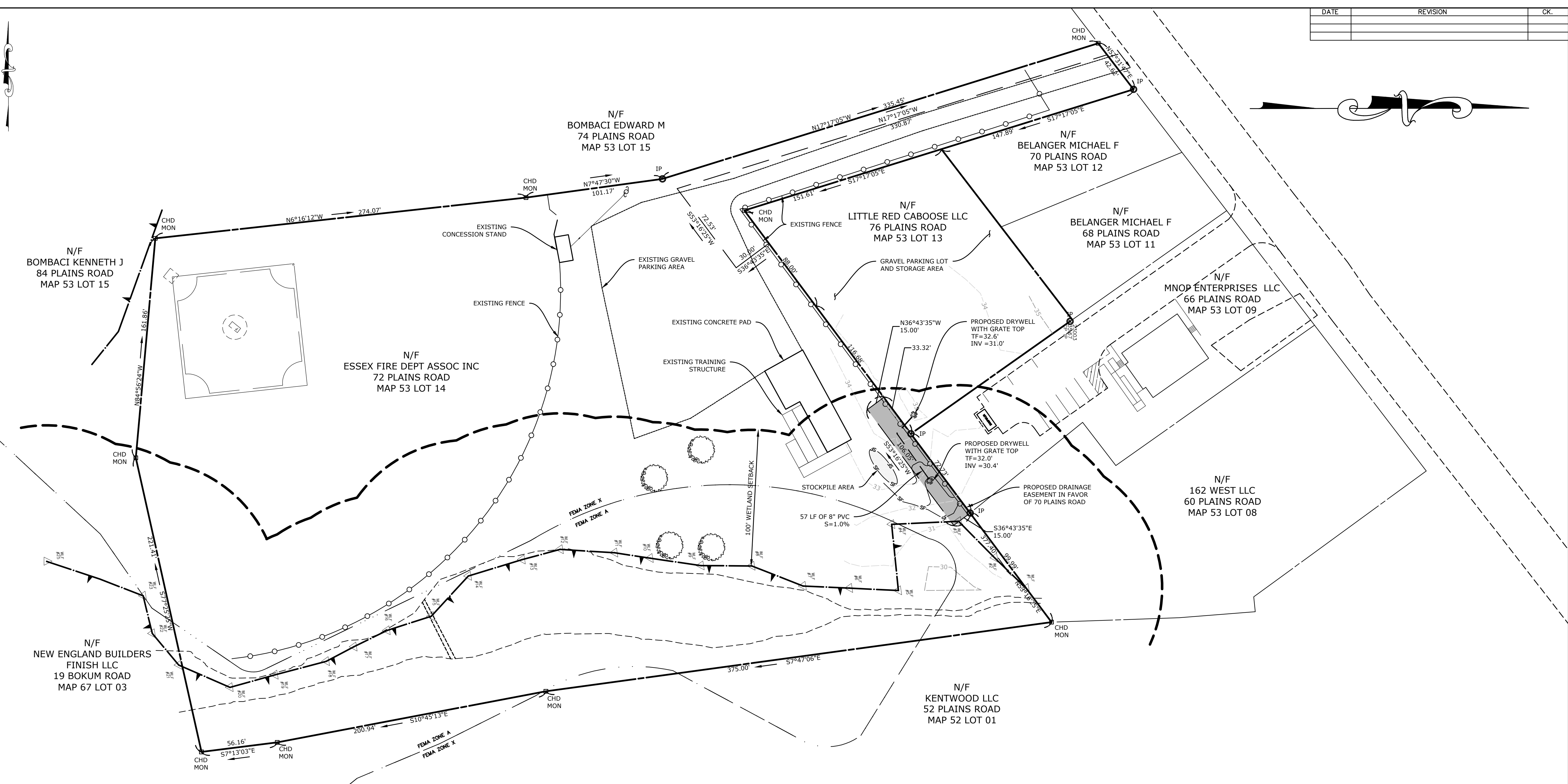

- CONSTRUCTION SEQUENCE:
1. INSTALL SILT FENCE
 2. STRIP AND STOCKPILE TOPSOIL
 3. INSTALL DRY WELLS AND PIPE AS SHOWN HEREON
 4. BACKFILL AND GRADE TO FORM SWALE
 5. PLACE AND GRADE TOPSOIL ON ALL DISTURBED AREAS
 6. SEED, FERTILIZER AND MULCH ALL DISTURBED AREAS
 7. MAINTAIN SILT FENCE UNTIL A PERMANENT GRASS GROWTH HAS BEEN ESTABLISHED

THIS SURVEY AND MAP HAVE BEEN PREPARED IN ACCORDANCE WITH SECTIONS 20-300B-1 THRU 20-300B-20 OF THE REGULATIONS OF CONNECTICUT STATE AGENCIES "MINIMUM STANDARDS FOR SURVEYS AND MAPS IN THE STATE OF CONNECTICUT". IT IS AN IMPROVEMENT LOCATION INTENDED TO DEPICT EXISTING AND PROPOSED IMPROVEMENTS.

PROPERTY BOUNDARY HAS BEEN ESTABLISHED BY A DEPENDENT RESURVEY WITH REFERENCE TO THE MAP NOTED HEREON.

HORIZONTAL ACCURACY CONFORMS TO CLASS A-2.

VERTICAL ACCURACY CONFORMS TO CLASS T-2 (U.S.G.S. DATUM) FOR THE SUBJECT PROPERTY REFERENCE IS MADE TO THE FOLLOWING DEED(S) ON FILE IN THE TOWN OF ESSEX: B 103/P 889 AND B 321/P 137

THIS SITE IS LOCATED WITHIN FLOOD ZONE (A) AND ZONE X PER FIRM COMMUNITY PANEL NUMBER 090065 0331 G MAP EFFECTIVE DATE AUGUST 28, 2008

TO MY KNOWLEDGE AND BELIEF, THIS MAP IS SUBSTANTIALLY CORRECT AS NOTED HEREON.

Robert L. Doane, Jr.
ROBERT L. DOANE, JR.
CONN. P.E. & L.S. LIC. NO. 11483

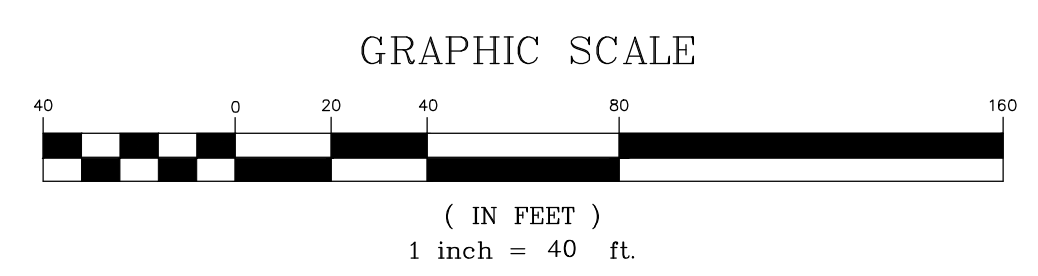
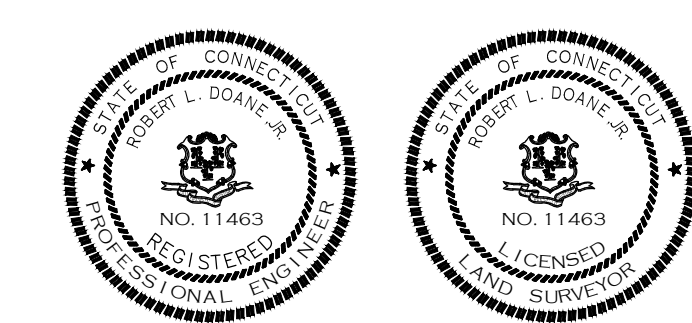

MAP # 53 LOT # 14

DOANE ENGINEERING
CIVIL ENGINEERING AND LAND SURVEYING
P.O. BOX 113 CENTERBROOK, CONNECTICUT 06409
TEL: (860)767-0138, FAX: (860)767-9104

EASEMENT PLAN
PREPARED FOR
LITTLE RED CABOOSE LLC
ESSEX FIRE DEPT ASSOC INC
76 & 72 PLAINS ROAD, ESSEX, CONNECTICUT

SCALE: 1"=40'	DATE: 07/29/22	SHEET NO.: 1 OF 1	IDENT. NO.:
------------------	-------------------	----------------------	-------------